

Model 3321/3322 LCZ Meter

Service Manual

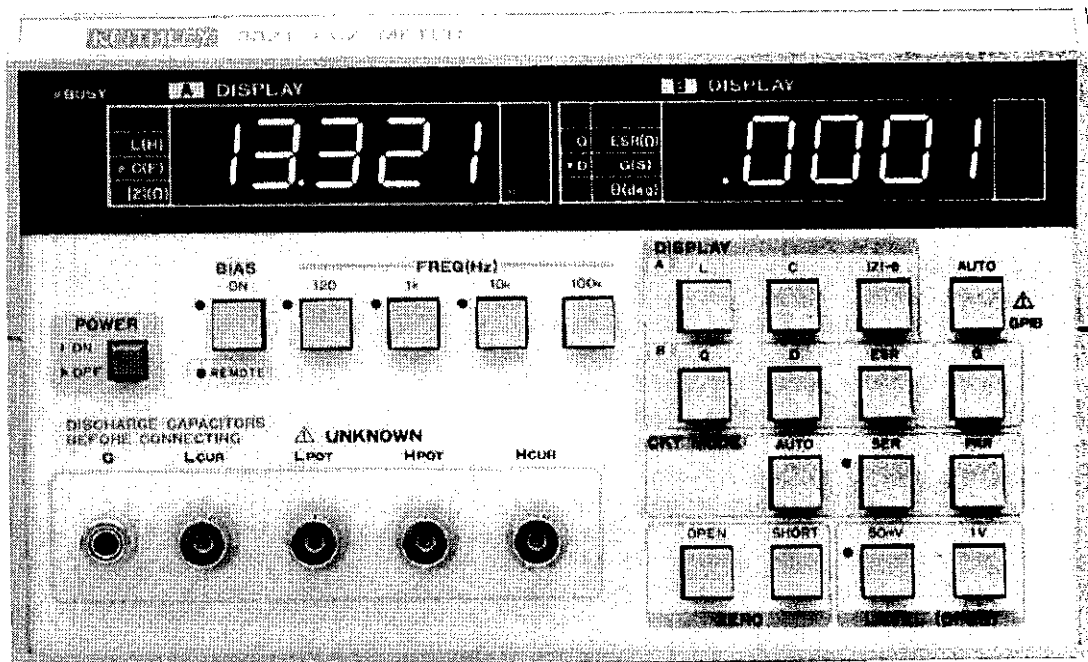

Contains Operating and Servicing Information

KEITHLEY

WARRANTY

Keithley Instruments, Inc. warrants this product to be free from defects in material and workmanship for a period of 1 year from date of shipment.

Keithley Instruments, Inc. warrants the following items for 90 days from the date of shipment: probes, cables, rechargeable batteries, diskettes, and documentation.

During the warranty period, we will, at our option, either repair or replace any product that proves to be defective.

To exercise this warranty, write or call your local Keithley representative, or contact Keithley headquarters in Cleveland, Ohio. You will be given prompt assistance and return instructions. Send the product, transportation prepaid, to the indicated service facility. Repairs will be made and the product returned, transportation prepaid. Repaired or replaced products are warranted for the balance of the original warranty period, or at least 90 days.

LIMITATION OF WARRANTY

This warranty does not apply to defects resulting from product modification without Keithley's express written consent, or misuse of any product or part. This warranty also does not apply to fuses, software, non-rechargeable batteries, damage from battery leakage, or problems arising from normal wear or failure to follow instructions.

THIS WARRANTY IS IN LIEU OF ALL OTHER WARRANTIES, EXPRESSED OR IMPLIED, INCLUDING ANY IMPLIED WARRANTY OF MERCHANTABILITY OR FITNESS FOR A PARTICULAR USE. THE REMEDIES PROVIDED HEREIN ARE BUYER'S SOLE AND EXCLUSIVE REMEDIES.

NEITHER KEITHLEY INSTRUMENTS, INC. NOR ANY OF ITS EMPLOYEES SHALL BE LIABLE FOR ANY DIRECT, INDIRECT, SPECIAL, INCIDENTAL OR CONSEQUENTIAL DAMAGES ARISING OUT OF THE USE OF ITS INSTRUMENTS AND SOFTWARE EVEN IF KEITHLEY INSTRUMENTS, INC., HAS BEEN ADVISED IN ADVANCE OF THE POSSIBILITY OF SUCH DAMAGES. SUCH EXCLUDED DAMAGES SHALL INCLUDE, BUT ARE NOT LIMITED TO: COSTS OF REMOVAL AND INSTALLATION, LOSSES SUSTAINED AS THE RESULT OF INJURY TO ANY PERSON, OR DAMAGE TO PROPERTY.



Keithley Instruments, Inc. • 28775 Aurora Road • Cleveland, OH 44139 • 440-248-0400 • Fax: 440-248-6168 • <http://www.keithley.com>

BELGIUM:	Keithley Instruments B.V.	Bergensesteenweg 709 • B-1600 Sint-Pieters-Leeuw • 02/363 00 40 • Fax: 02/363 00 64
CHINA:	Keithley Instruments China	Yuan Chen Xin Building, Room 705 • 12 Yumin Road, Dewai, Madian • Beijing 100029 • 8610-62022886 • Fax: 8610-62022892
FRANCE:	Keithley Instruments Sarl	B.P. 60 • 3, allée des Garays • 91122 Palaiseau Cédex • 01 64 53 20 20 • Fax: 01 60 11 77 26
GERMANY:	Keithley Instruments GmbH	Landsberger Strasse 65 • D-82110 Germering • 089/84 93 07-40 • Fax: 089/84 93 07-34
GREAT BRITAIN:	Keithley Instruments Ltd	The Minster • 58 Portman Road • Reading, Berkshire RG30 1EA • 0118-9 57 56 66 • Fax: 0118-9 59 64 69
INDIA:	Keithley Instruments GmbH	Flat 2B, WILOCRISSA • 14, Rest House Crescent • Bangalore 560 001 • 91-80-509-1320/21 • Fax: 91-80-509-1322
ITALY:	Keithley Instruments s.r.l.	Viale S. Gimignano, 38 • 20146 Milano • 02/48 30 30 08 • Fax: 02/48 30 22 74
NETHERLANDS:	Keithley Instruments B.V.	Postbus 559 • 4200 AN Gorinchem • 0183-635333 • Fax: 0183-630821
SWITZERLAND:	Keithley Instruments SA	Kriesbachstrasse 4 • 8600 Dübendorf • 01-821 94 44 • Fax: 01-820 30 81
TAIWAN:	Keithley Instruments Taiwan	1 Fl. 85 Po Ai Street • Hsinchu, Taiwan, R.O.C. • 886-3572-9077 • Fax: 886-3572-903

Model 3321/3322 LCZ Meter Service Manual

© 1991, Keithley Instruments, Inc.
Test Instrumentation Group
All rights reserved.
Cleveland, Ohio, U.S.A.
August 1991, First Printing
Document Number: 3321-902-01 Rev. A

All Keithley product names are trademarks or registered trademarks of Keithley Instruments, Inc.

Other brand and product names are trademarks or registered trademarks of their respective holders.

Safety Precautions

The following safety precautions should be observed before using the Model 3321 / 3322 LCZ Meter and any associated instruments.

This instrument is intended for use by qualified personnel who recognize shock hazards and are familiar with the safety precautions required to avoid possible injury. Read over this manual carefully before using the instrument.

Exercise extreme caution when a shock hazard is present at the test circuit. The American National Standards Institute (ANSI) states that a shock hazard exists when voltage levels greater than 30V rms or 42.4V peak are present. A **good safety practice is to expect that hazardous voltage is present in any unknown circuit before measuring.**

Inspect the connecting cables and test leads for possible wear, cracks, or breaks before each use.

For maximum safety, do not touch the test cables or any instruments while power is applied to the circuit under test. Turn off the power and discharge any capacitors before connecting or disconnecting cables from the instrument.

Do not touch any object which could provide a current path to the common side of the circuit under test or power line (earth) ground. Always make measurements with dry hands while standing on a dry, insulated surface capable of withstanding the voltage being measured.

Instrumentation and accessories should not be connected to humans.

HOW TO USE THIS MANUAL

Details procedures to verify that the instrument meets stated specifications.

SECTION 1 Performance Verification

Describes basic operating principles for the various circuits in the Model 3321/3322.

SECTION 2 Principles of Operation

Covers fuse replacement, calibration and repair of the instrument, and lists replacement parts.

SECTION 3 Service Information

WARNING

The information in this manual is intended for qualified service personnel who can recognize possible shock hazards. Do not attempt these procedures unless you are qualified to do so.

Table of Contents

SECTION 1 — Performance Verification

1.1	INTRODUCTION	1-1
1.2	INITIAL CONDITIONS	1-1
1.3	LINE POWER	1-1
1.4	VERIFICATION LIMITS	1-1
1.5	MEASUREMENT SIGNAL TESTS	1-2
1.5.1	Environmental Conditions	1-2
1.5.2	Recommended Test Equipment	1-2
1.5.3	Frequency Accuracy	1-2
1.5.4	Measurement Signal Level Accuracy	1-3
1.5.5	Measurement Signal Distortion	1-4
1.5.6	Output Impedance Accuracy	1-5
1.5.7	Internal Bias Voltage Accuracy	1-6
1.5.8	External DC Bias Voltage Range	1-7
1.6	MEASUREMENT ACCURACY TESTS	1-8
1.6.1	Environmental Conditions	1-8
1.6.2	Recommended Equipment	1-8
1.6.3	Resistance Standards Accuracy	1-8
1.6.4	Resistance Measurement Accuracy	1-9
1.6.5	Capacitance Reading Checks	1-12
1.6.6	Inductance Reading Checks	1-12

SECTION 2 — Principles of Operation

2.1	INTRODUCTION	2-1
2.2	BLOCK DIAGRAMS	2-1
2.3	CURRENT AND VOLTAGE DETECTION	2-1
2.4	IMPEDANCE CALCULATION	2-1
2.5	OSCILLATOR	2-4
2.6	CURRENT-TO-VOLTAGE CONVERTER	2-4
2.7	ANALYZER	2-5

SECTION 3 — Service Information

3.1	INTRODUCTION	3-1
3.2	FUSE REPLACEMENT	3-1
3.2.1	Line Fuse	3-1
3.2.2	External Bias Fuse	3-1
3.3	CALIBRATION	3-1
3.4	FAN FILTER CLEANING	3-2
3.5	REPAIR	3-2
3.5.1	Factory Service	3-2

3.5.2	Cover Removal	3-2
3.5.3	Battery Replacement	3-3
3.5.4	Operation Check	3-4
3.5.5	Repair Summary	3-4
3.6	REPLACEABLE PARTS	3-5
3.6.1	Parts List	3-5
3.6.2	Ordering Parts	3-5

APPENDICES

- A Model 3321 Specifications
- B Model 3322 Specifications

List of Illustrations

SECTION 1 — Performance Verification

Figure 1-1	Connections for Frequency Accuracy Measurement	1-3
Figure 1-2	Connections for Measurement Signal Level Accuracy	1-3
Figure 1-3	Connections for Distortion Measurements	1-4
Figure 1-4	Connections for Output Impedance Accuracy Tests	1-5
Figure 1-5	Connections for Internal Bias Voltage Accuracy Tests	1-6
Figure 1-6	Connections for External Bias Voltage Range Tests	1-7
Figure 1-7	Connections for Resistance Measurement Accuracy Measurements	1-9
Figure 1-8	Connections for Capacitance and Inductance Reading Checks	1-13

SECTION 2 — Principles of Operation

Figure 2-1	Measuring System Block Diagram	2-2
Figure 2-2	Hardware Block Diagram	2-3
Figure 2-3	Oscillator Block Diagram	2-4
Figure 2-4	Current-to-Voltage Converter	2-5
Figure 2-5	Analyzer	2-5

SECTION 3 — Service Information

Figure 3-1	Cover Removal	3-3
Figure 3-2	Exploded View	3-6

List of Tables

SECTION 1 — Performance Verification

Table 1-1	Recommended Test Equipment for Measurement Signal Tests	1-2
Table 1-2	Measurement Signal Level Accuracy	1-4
Table 1-3	Distortion Measurement Summary	1-4
Table 1-4	Recommended Equipment for Measurement Accuracy Tests	1-8
Table 1-5	Resistance Accuracy Reading Limits ($ Z $) for 1Vrms Level	1-10
Table 1-6	Resistance Accuracy Reading Limits (θ) for 1Vrms Level	1-10
Table 1-7	Resistance Accuracy Reading Limits ($ Z $) for 50mVrms Level	1-11
Table 1-8	Resistance Accuracy Reading Limits (θ) for 50mVrms Level	1-11

SECTION 3 — Service Information

Table 3-1	Recommended Line Fuses	3-1
Table 3-2	Self-calibration Errors	3-4
Table 3-3	Operation Check Problem Summary	3-4
Table 3-4	Measurement Signal Problem Summary	3-5
Table 3-5	Model 3321 Replaceable Parts	3-7
Table 3-6	Model 3322 Replaceable Parts	3-7

SECTION 1

Performance Verification

1.1 INTRODUCTION

The procedures outlined in this section may be used to *verify that the Model 3321/3322 LCZ Meter is operating within limits stated in the specifications*. Performance verification may be done when the instrument is first received to ensure that no damage or misadjustment has occurred during shipment. Verification may also be performed whenever there is a question of instrument accuracy, if desired.

NOTE

If instrument performance is outside the specified range, and the instrument is still under warranty, contact your Keithley representative or the factory to determine the correct course of action.

Performance verification falls into the following two general categories:

- Measurement signal tests (paragraph 1.5)
- Measurement accuracy and reading checks (paragraph 1.6)

1.2 INITIAL CONDITIONS

The Model 3321/3322 should be turned on and allowed to warm up for at least one hour before performing the verification procedures. (The test equipment should also be allowed to warm up for the time period recommended by the manufacturer.) If the instrument has been subjected to extreme temperature or humidity, allow additional time for internal circuits to reach normal operating temperature. Typically, it takes one additional hour to stabilize a unit that is 10°C (18°F) outside the specified temperature range.

1.3 LINE POWER

Be sure to set the line voltage switch on the rear panel to the *correct line voltage*. The instrument should be tested while operating on a line voltage within $\pm 5\%$ of the line voltage switch setting and at a line frequency from 48Hz to 62Hz.

1.4 VERIFICATION LIMITS

The performance verification limits stated in this section reflect only the accuracy specifications of the Model 3321/3322. They do not include test equipment tolerance.

1.5 MEASUREMENT SIGNAL TESTS

Measurement signal tests measure various characteristics of the test signal that is applied to the DUT. These tests include:

- Frequency accuracy
- Measurement signal level accuracy
- Measurement signal distortion
- Output impedance accuracy
- Internal DC bias voltage accuracy
- External DC bias voltage range

1.5.1 Environmental Conditions

All measurement signal tests should be performed at an ambient temperature of $23^{\circ} \pm 5^{\circ}\text{C}$ and at a relative humidity of $50\% \pm 30\%$.

1.5.2 Recommended Test Equipment

Table 1-1 lists the test equipment required to perform the measurement signal tests. The procedures for measurement signal verification tests are based on using this exact equipment. Alternate equipment may be used as long as that equipment has specifications at least good as those stated in Table 1-1.

1.5.3 Frequency Accuracy

1. Connect the Model 3321 / 3322 H CUR jack to input A of the counter / timer, as shown in Figure 1-1. Be sure to connect the G terminal of the LCZ meter to the shield of the connecting cable as shown.
2. Set the LCZ meter operating modes as follows:
FREQ: 1kHz
LEVEL: 1Vrms
BIAS: OFF
3. Set the counter / timer to measure frequency on input A.
4. Verify that the counter reading is between 0.999950kHz and 1.000050kHz.

Table 1-1. Recommended Test Equipment for Measurement Signal Tests

Manufacturer	Model	Description	Specifications
Keithley	197A	DMM (AC volts, DC volts, 5-1/2 digits)	2VDC range; $\pm(0.015\%$ of rdg+3 counts) 2VAC range; $\pm(0.35\%$ of rdg+100 counts) 200mVAC range; $\pm(0.35\%$ of rdg+3 counts)
Philips	PM 6654C	Timer/Counter	0.01Hz-120MHz; time base aging
	PM 9678	TXCO option	$<1 \times 10^7$ /month
Panasonic	VP-7722A	Audio analyzer	10Hz-110kHz; 0.01% accuracy at fullscale; $\pm 1\text{dB}$ harmonic distortion accuracy from 10Hz to 15.99kHz
Keithley	1681	DC power supply	0-40VDC adjustable, $<5\text{mVp-p}$ ripple
		Test leads	Two leads terminated with banana plug and clip-on probes
Keithley	7051-2	BNC interconnect cable	50 Ω coaxial cable (RG-58C), male BNC connectors, 2ft.(0.6m)
Keithley	7754-3	BNC to alligator cable	Coaxial cable, male BNC connector, two alligator clips
Keithley	3324	Test leads	4-terminal alligator clip test lead set
Keithley	3325	Test leads	Kelvin clip test lead set
Pomona	1468	BNC-banana adapter	Female BNC connector to double banana plug
		Capacitor	10 μF , 100VDC
		Resistor	100 Ω 0.5%, 1/2W
		Switch	Single-pole, single-throw

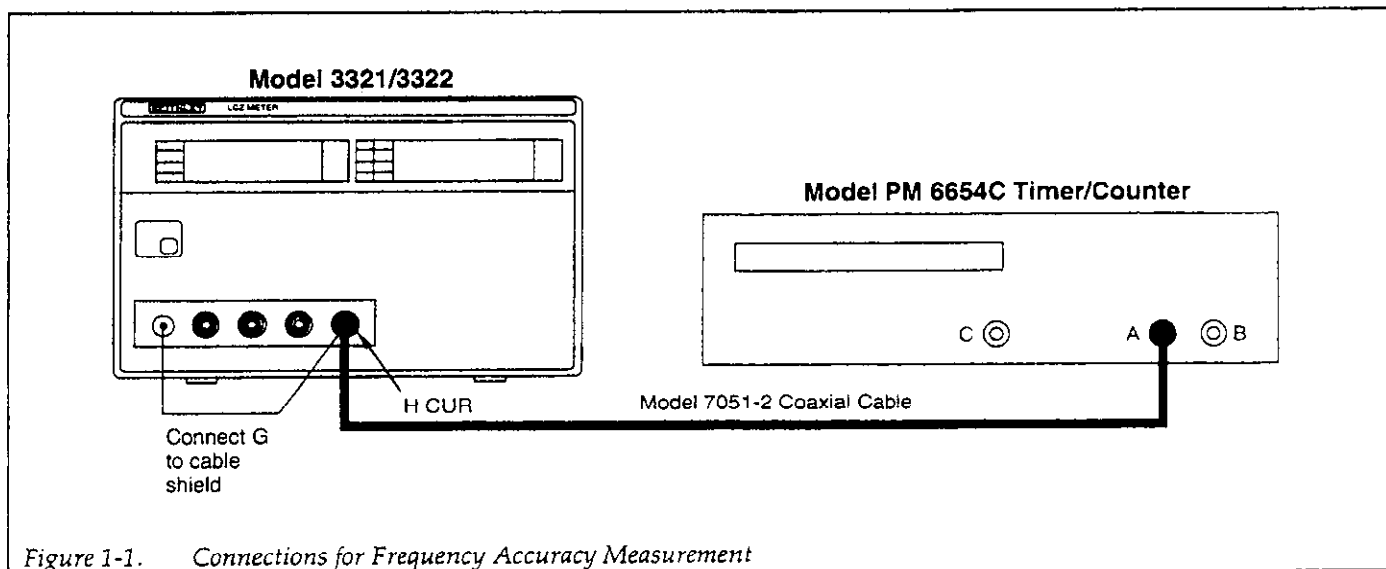

Figure 1-1. Connections for Frequency Accuracy Measurement

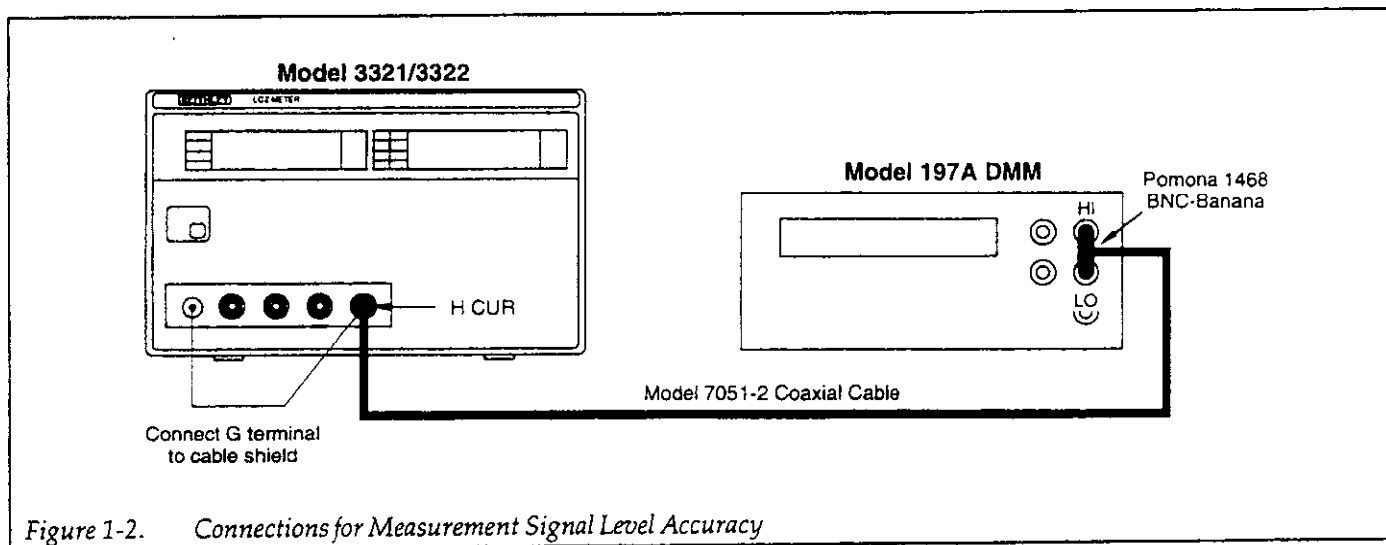

Figure 1-2. Connections for Measurement Signal Level Accuracy

1.5.4 Measurement Signal Level Accuracy

1. Connect the Model 3321/3322 H CUR jack to the DMM, as shown in Figure 1-2. Be sure to connect the G terminal of the LCZ meter to the shield of the connecting cable as shown.
2. Select the ACV function and auto-ranging on the DMM.
3. Set the LCZ meter operating modes as follows:

LEVEL: 1Vrms
FREQ: 120Hz
BIAS: OFF

4. Verify that the DMM reading is between the limits for 1Vrms, 120Hz operation, as summarized in Table 1-2.
5. Repeat steps 3 and 4 for 1kHz, 10kHz, and 100kHz.
6. Change the LEVEL to 50mVrms, and verify the signal level accuracy for 1kHz and 100kHz frequencies, as summarized in Table 1-2.

Table 1-2. Measurement Signal Level Accuracy

Level	Frequency	Signal Level Limits
1Vrms	120Hz	0.96 to 1.04Vrms
	1kHz	0.97 to 1.03Vrms
	10kHz	0.96 to 1.04Vrms
	100kHz	0.95 to 1.05Vrms
50mVrms	1kHz	47.5 to 52.5mVrms
	100kHz	46.3 to 53.7mVrms

5. Verify that the distortion reading is 0.5% or less.
NOTE: Perform the following steps for the Model 3322 LCZ Meter only.
6. Set the Model 3322 frequency to 200Hz as follows:
 - A. Press the SETUP key to enter the auxiliary setup mode. The LED above the FREQ (Hz) marking blinks, and the unit displays the present frequency in the **[B]** DISPLAY area.
 - B. Enter a frequency of 200Hz.
 - C. Press the ENTER/EXIT key twice to complete 200Hz programming.
7. Verify that the distortion reading is 0.3% or less.

1.5.5 Measurement Signal Distortion

1. Connect the H CUR jack of the LCZ meter to the distortion meter, as shown in Figure 1-3. Be sure to connect the G terminal of the LCZ meter to the cable shield as shown.
2. Set the LCZ meter operating modes as follows:
LEVEL: 1Vrms
BIAS: OFF
FREQ: 1kHz
3. Verify that the distortion reading is 0.3% or less, as summarized in Table 1-3.
4. Change the frequency to 100kHz.

Table 1-3. Distortion Measurement Summary

Frequency	Distortion Reading
200Hz*	≤0.3%
1kHz	≤0.3%
100kHz	≤0.5%

*Model 3322 only.

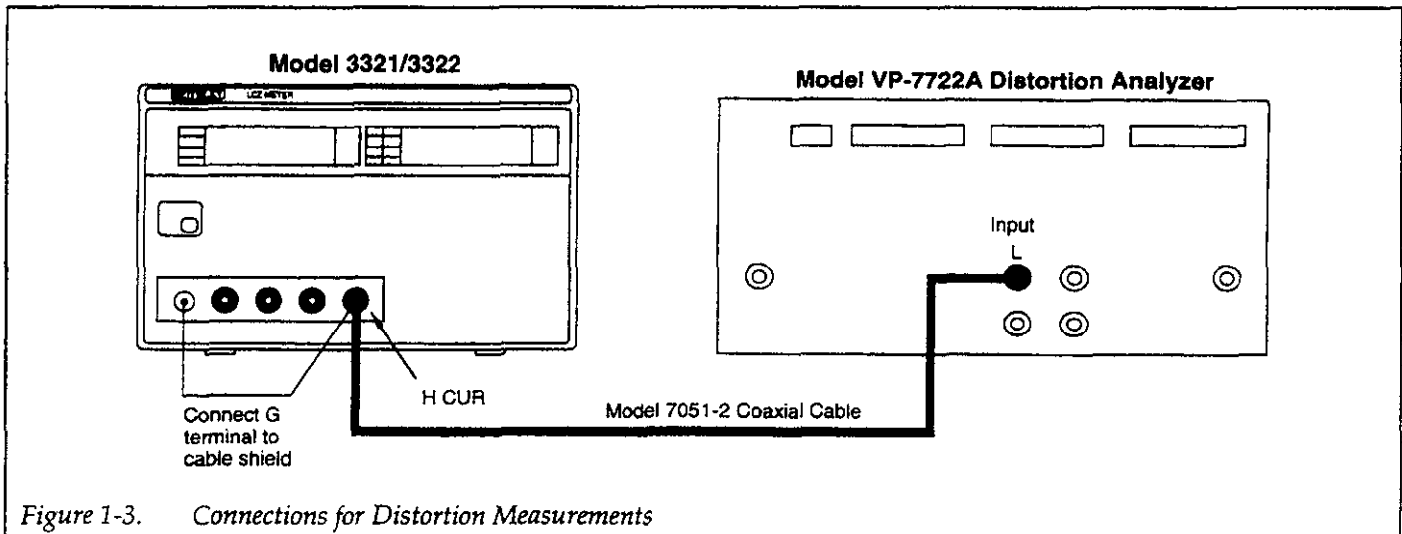

1.5.6 Output Impedance Accuracy

1. Connect the LCZ meter to the DMM, switch, and resistor, as shown in Figure 1-4. Be sure to connect the G terminal of the LCZ meter to the cable shield, and be sure the resistor and switch are connected as shown.
2. Select the 2VAC range on the DMM.
3. Set the LCZ meter operating modes as follows:
 FREQ: 1kHz
 LEVEL: 1Vrms
 BLAS: OFF

4. Set the switch to the open position, then note the DMM reading. Call this reading V_1 .
5. Set the switch to the closed position, then note the DMM reading. Call this reading V_2 .
6. Compute the output impedance from V_1 and V_2 as follows:

$$Z_{OUT} = 100 [(V_1/V_2) - 1] \Omega$$

7. Verify that the output impedance computed in step 6 is between 97Ω and 103Ω inclusive.

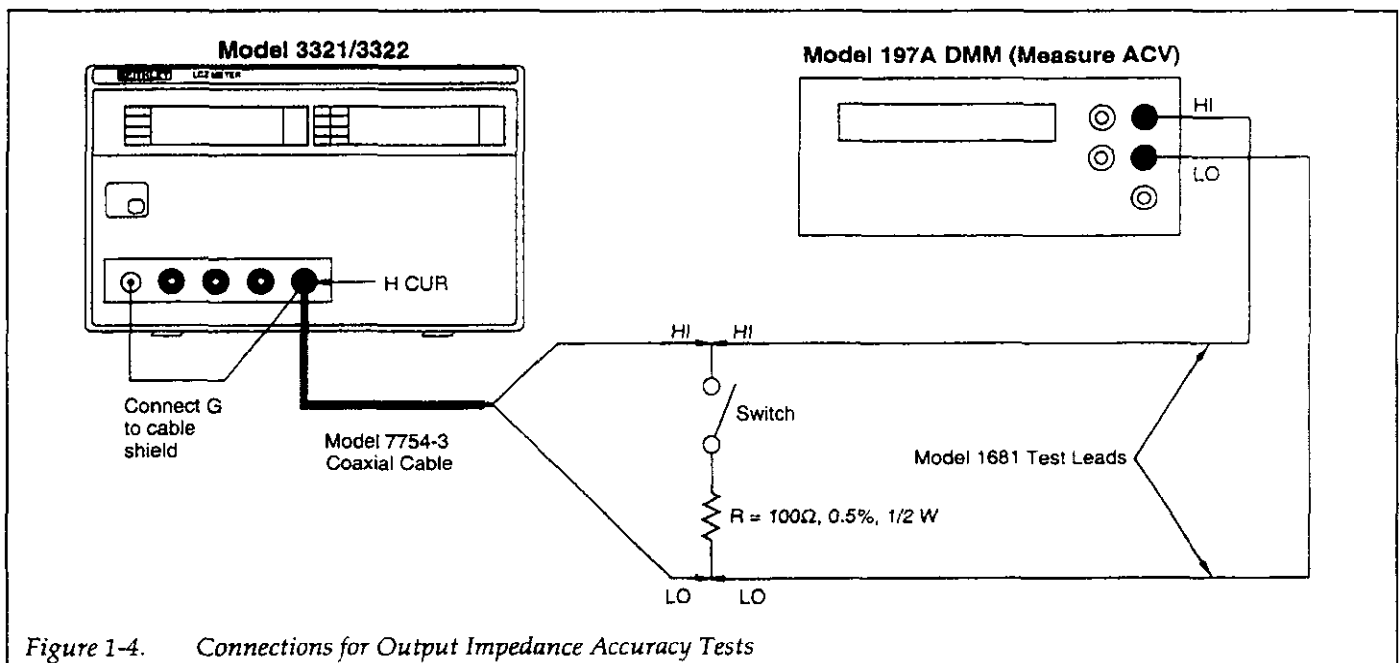

Figure 1-4. Connections for Output Impedance Accuracy Tests

1.5.7 Internal Bias Voltage Accuracy

1. Connect the LCZ meter to the DMM using the Model 3324 cables (see Figure 1-5). Note that connections are intended to measure the voltage between the H CUR and L CUR terminals.
2. Select the 2VDC range on the DMM.
3. Set the LCZ meter operating modes as follows:
A DISPLAY: C
LEVEL: 50mVrms

- RANGE: AUTO (Model 3322 only)
BIAS INT/EXT: INT (rear panel switch)
BIAS: ON
4. Verify that DMM reading is between 1.9V and 2.1V inclusive.
 5. Set the LCZ meter to BIAS OFF.
 6. Select the 200mVDC range on the DMM.
 7. Verify that the DMM reading is $0V \pm 10mV$.

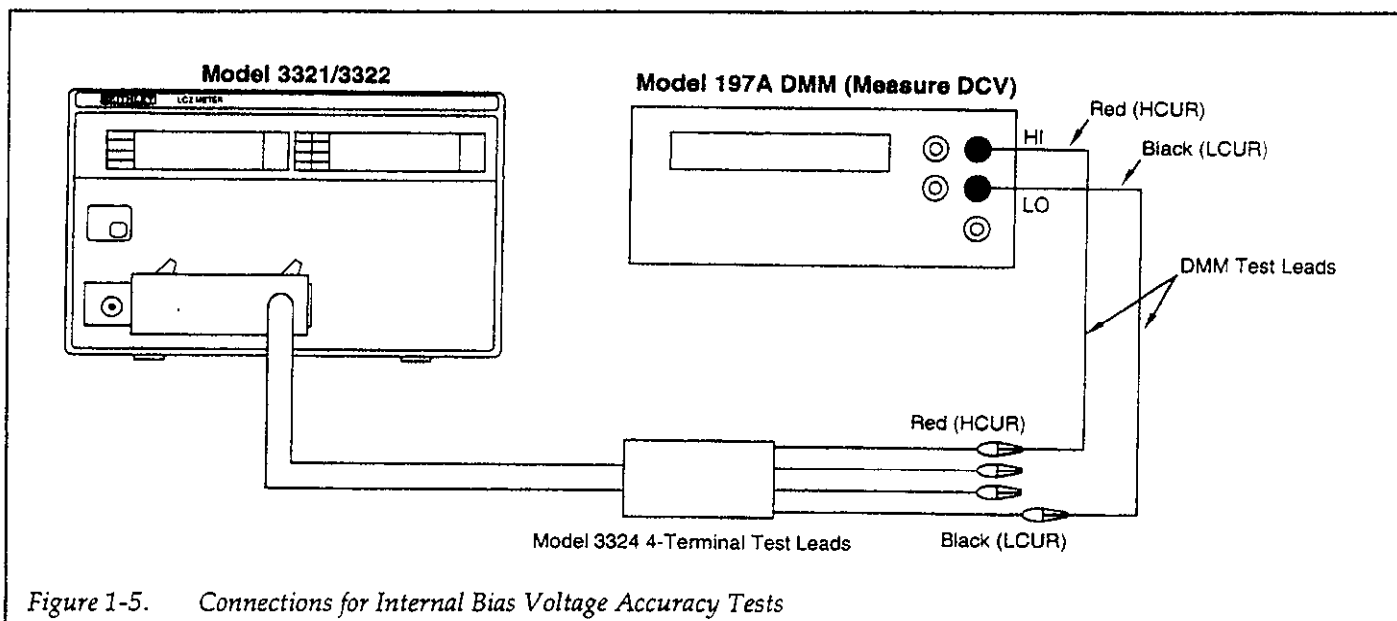

Figure 1-5. Connections for Internal Bias Voltage Accuracy Tests

1.5.8 External DC Bias Voltage Range

1. Connect the LCZ meter to the DC power supply, capacitor, and DMM, as shown in Figure 1-6.
2. Select the DCV function and auto-ranging on the DMM.
3. Set LCZ meter operating modes as follows:
A DISPLAY: C
 LEVEL: 50mVrms
 BIAS INT/EXT: EXT (rear panel switch)
 BIAS: ON or OFF as indicated below.
4. For the Model 3322 only, set the unit to RANGE 2 as follows:
 - A. Measure the value of the 10 μ F capacitor in the RANGE AUTO mode (DC BIAS OFF).
 - B. Verify that the Model 3322 is properly measuring the capacitor.
 - C. Press the RANGE/AUTO key, and check that the AUTO LED goes off. The unit is now set to RANGE 2.

5. Check the voltage across the capacitor with BIAS OFF, and with BIAS ON and a 0.35V external bias voltage setting on the DC power supply.
6. Disconnect the DMM, and measure the capacitor value. Verify that the reading is stable to within ± 2 digits of the center value (4 digits of span).
7. Connect the DMM to measure the voltage across the capacitor.

WARNING

Hazardous voltage (>30V) will be used in the following steps. Do not touch the capacitor until the test is complete and the capacitor is discharged.

8. Gradually increase the external DC power supply to +40V.
9. Verify that the external bias fuse does not blow with 40V applied.
10. Gradually decrease the external DC power supply to 0V, then disconnect the capacitor.

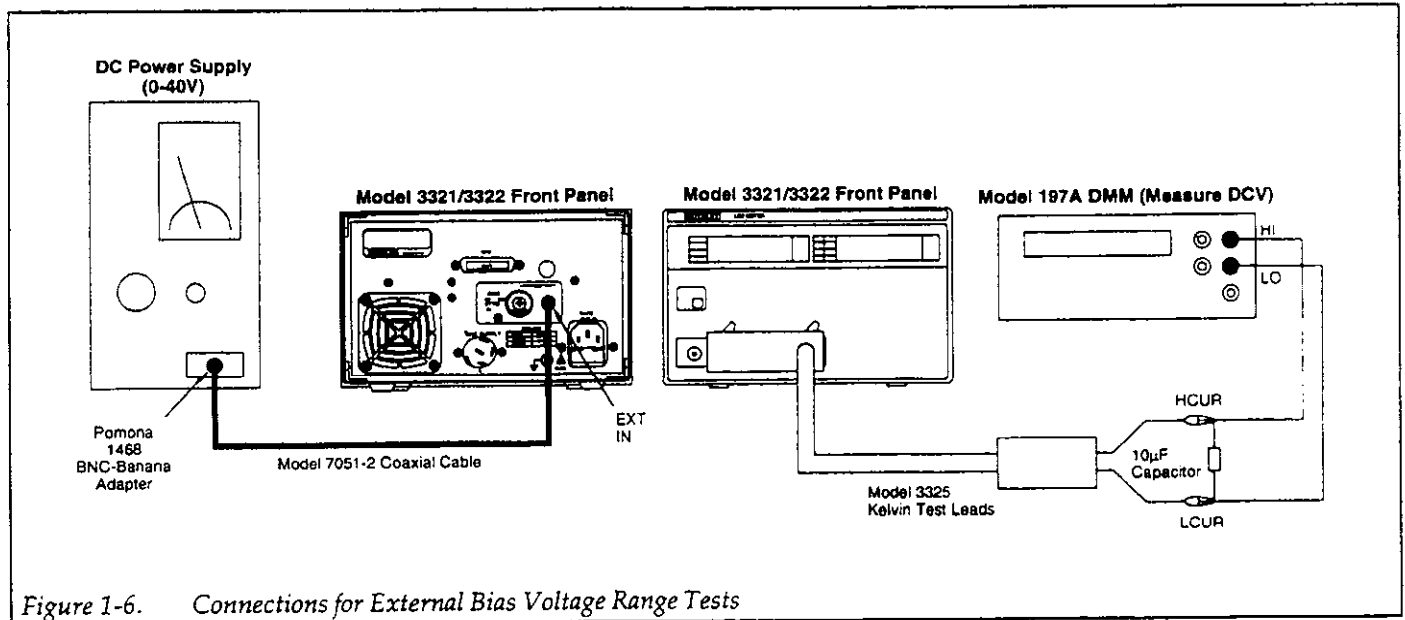

1.6 MEASUREMENT ACCURACY TESTS

Measurement accuracy tests include:

- R (resistance) measurement accuracy
- C (capacitance) reading checks
- L (inductance) reading checks

1.6.1 Environmental Conditions

All resistance measurement accuracy tests should be performed at an ambient temperature of $23^{\circ} \pm 1^{\circ}\text{C}$ and at a relative humidity of $50\% \pm 20\%$. Capacitance and inductance reading checks can be performed at $23^{\circ} \pm 5^{\circ}\text{C}$.

1.6.2 Recommended Equipment

Table 1-4 lists the resistance standards, capacitors, inductors, and additional equipment required to perform the measurement accuracy tests. The procedures for resistance measurement accuracy verification tests are based on using these standards. Listed capacitors and inductors are to be used to perform capacitance and inductance

reading checks that are not based on instrument accuracy specifications.

NOTE

The Model 3321/3322 makes all measurements based on the magnitude and phase of the impedance of the DUT connected to the UNKNOWN terminals. For that reason, verification of resistance measurement accuracy is sufficient to guarantee the accuracy of capacitance and inductance measurements. The resistance standards values used are the same as those use for calibration. Capacitance and inductance reading checks are included to verify that the instrument properly displays capacitance and inductance values.

1.6.3 Resistance Standards Accuracy

Resistance standards used for the measurement accuracy tests should be calibrated at certain intervals so as to ensure the accuracy of standards values. Standards accuracy tolerances should be added to the stated measurement limits.

Table 1-4. Recommended Equipment for Measurement Accuracy Tests

Description	Manufacturer/Model	Values
Resistance standards	Hewlett-Packard HP 16074A Calibration Standard	OPEN, SHORT, 100 Ω , 1k Ω , 10k Ω , 100k Ω
Capacitors	User supplied	100pF, 0.01 μF , $\pm 1\%$
Inductors	User supplied	100 μH , 10mH, $\pm 1\%$
Test Fixture*	Keithley 3323	

* Test fixture used to connect capacitors and inductors for testing.

1.6.4 Resistance Measurement Accuracy

Resistance accuracy measurements are made using the resistance standards listed in Table 1-4 and the test connections shown in Figure 1-7.

NOTE

Be sure to connect the H and L terminals of the resistance standards to the H and L terminals respectively of the LCZ meter, or inaccurate measurements may result.

Procedure:

1. Set the Model 3321/3322 operating modes as follows:

A DISPLAY: Z

B DISPLAY: θ

FREQ: 120Hz

LEVEL: 1Vrms

SPEED: MED (Model 3322 only)

RANGE: AUTO (Model 3322 only)

2. Connect the OPEN resistance standard to the instrument, then press ZERO OPEN. Allow the instrument to complete the zero cycle before proceeding.
3. Connect the SHORT resistance standard to the instrument, then press ZERO SHORT. Allow the instrument to complete the zero cycle before proceeding.
4. Connect the 100 Ω resistance standard to the instrument, and allow the reading to settle.
5. Verify that the $|Z|$ and θ readings are within the limits shown in Table 1-5 and Table 1-6 respectively.
6. Repeat steps 4 and 5 for the remaining standard values listed in the table (1k Ω through 100k Ω), and verify that all readings are within the required limits.
7. Repeat steps 4 through 6 for the remaining frequencies listed in the tables. Note that the Model 3321 is to be tested only at the following frequencies: 120Hz, 1kHz, 10kHz, and 100kHz.
8. Change the LEVEL to 50mVrms, then repeat steps 2 through 7 for the following frequencies: 120Hz, 1kHz, 10kHz, 100kHz. Refer to Table 1-7 and Table 1-8 for 50mV limits.

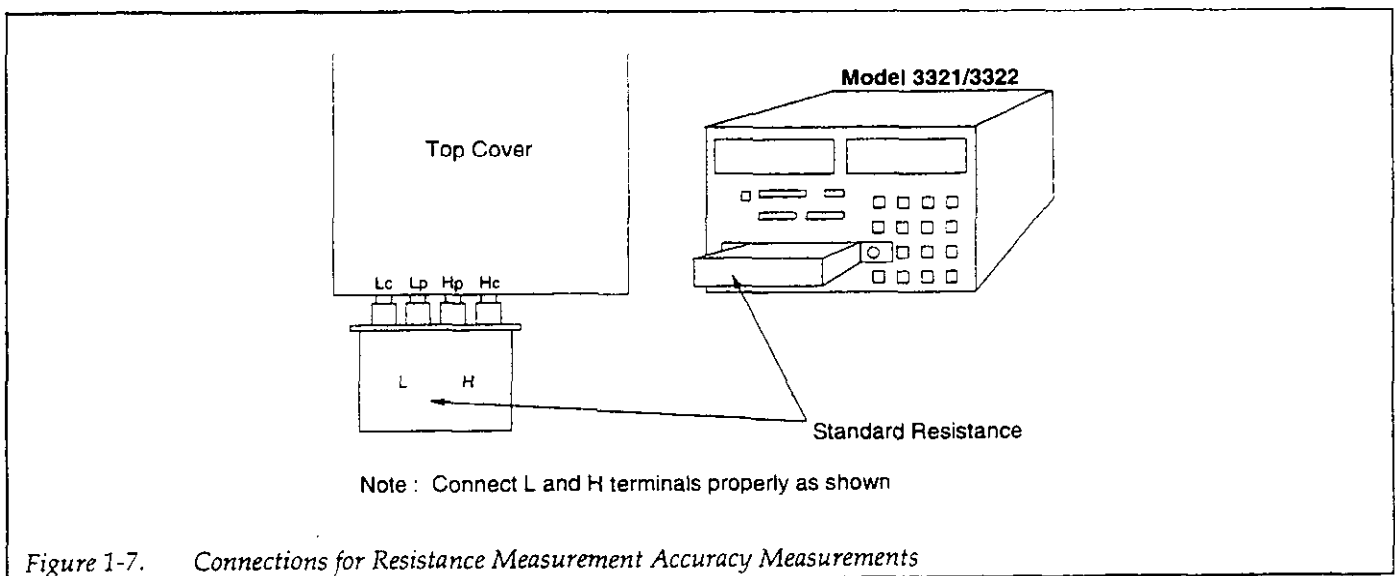

Figure 1-7. Connections for Resistance Measurement Accuracy Measurements

Table 1-5. Resistance Accuracy Reading Limits ($|Z|$) for 1Vrms Level

Resistance Standard Value	$ Z $ Reading Limits ($23^\circ \pm 1^\circ\text{C}$) at Indicated Frequency (Hz)							
	100* 120	200* 500*	1k	2k* 5k*	10k	20k*	50k*	100k
100 Ω	99.87 to 100.13 Ω	99.89 to 100.11 Ω	99.9 to 100.1 Ω	99.89 to 100.11 Ω	99.87 to 100.13 Ω	99.83 to 100.17 Ω	99.6 to 100.4 Ω	99.3 to 100.7 Ω
1k Ω	0.9987 to 1.0013k Ω	0.9989 to 1.0011k Ω	0.999 to 1.001k Ω	0.9989 to 1.0011k Ω	0.9987 to 1.0013k Ω	0.9983 to 1.0017k Ω	0.996 to 1.004k Ω	0.993 to 1.007k Ω
10k Ω	9.986 to 10.014k Ω	9.988 to 10.012k Ω	9.99 to 10.01k Ω	9.988 to 10.012k Ω	9.985 to 10.015k Ω	9.98 to 10.02k Ω	9.96 to 10.04k Ω	9.92 to 10.02k Ω
100k Ω	99.85 to 100.15k Ω	99.88 to 100.12k Ω	99.9 to 100.1k Ω	99.82 to 100.18k Ω	99.75 to 100.25k Ω	99.7 to 100.3k Ω	99.4 to 100.6k Ω	98.8 to 101.2k Ω

*Model 3322 only.

NOTE: Limits shown do not include resistance standards tolerances.

Table 1-6. Resistance Accuracy Reading Limits (θ) for 1Vrms Level

Resistance Standard Value	θ Reading Limits ($23^\circ \pm 1^\circ\text{C}$) at Indicated Frequency (Hz)							
	100* 120	200* 500*	1k	2k* 5k*	10k	20k*	50k*	100k
100 Ω	$0^\circ \pm 0.08^\circ$	$0^\circ \pm 0.05^\circ$	$0^\circ \pm 0.03^\circ$	$0^\circ \pm 0.08^\circ$	$0^\circ \pm 0.1^\circ$	$0^\circ \pm 0.15^\circ$	$0^\circ \pm 0.25^\circ$	$0^\circ \pm 0.5^\circ$
1k Ω	$0^\circ \pm 0.08^\circ$	$0^\circ \pm 0.05^\circ$	$0^\circ \pm 0.03^\circ$	$0^\circ \pm 0.06^\circ$	$0^\circ \pm 0.1^\circ$	$0^\circ \pm 0.15^\circ$	$0^\circ \pm 0.25^\circ$	$0^\circ \pm 0.6^\circ$
10k Ω	$0^\circ \pm 0.09^\circ$	$0^\circ \pm 0.05^\circ$	$0^\circ \pm 0.03^\circ$	$0^\circ \pm 0.06^\circ$	$0^\circ \pm 0.08^\circ$	$0^\circ \pm 0.12^\circ$	$0^\circ \pm 0.3^\circ$	$0^\circ \pm 0.6^\circ$
100k Ω	$0^\circ \pm 0.1^\circ$	$0^\circ \pm 0.06^\circ$	$0^\circ \pm 0.04^\circ$	$0^\circ \pm 0.08^\circ$	$0^\circ \pm 0.15^\circ$	$0^\circ \pm 0.2^\circ$	$0^\circ \pm 0.4^\circ$	$0^\circ \pm 0.8^\circ$

*Model 3322 only.

Table 1-7. Resistance Accuracy Reading Limits ($|Z|$) for 50mVrms Level

Resistance Standard Value	$ Z $ Reading Limits ($23^\circ \pm 1^\circ\text{C}$) at Indicated Frequency (Hz)			
	120	1k	10k	100k
100 Ω	99.8 to 100.2 Ω	99.85 to 100.15 Ω	99.77 to 100.23 Ω	98.4 to 101.6 Ω
1k Ω	0.998 to 1.002k Ω	0.9985 to 1.0015k Ω	0.9977 to 1.0023k Ω	0.984 to 1.016k Ω
10k Ω	9.975 to 10.025k Ω	9.984 to 10.016k Ω	9.976 to 10.024k Ω	9.8 to 10.2k Ω
100k Ω	99.7 to 100.3k Ω	99.84 to 100.16k Ω	99.68 to 100.32k Ω	97 to 103k Ω

NOTE: Limits shown do not include resistance standards tolerances.

Table 1-8. Resistance Accuracy Reading Limits (θ) for 50mVrms Level

Resistance Standard Value	θ Reading Limits ($23^\circ \pm 1^\circ\text{C}$) at Indicated Frequency (Hz)			
	120	1k	10k	100k
100 Ω	$0^\circ \pm 0.12^\circ$	$0^\circ \pm 0.06^\circ$	$0^\circ \pm 0.13^\circ$	$0^\circ \pm 1^\circ$
1k Ω	$0^\circ \pm 0.12^\circ$	$0^\circ \pm 0.06^\circ$	$0^\circ \pm 0.13^\circ$	$0^\circ \pm 1^\circ$
10k Ω	$0^\circ \pm 0.15^\circ$	$0^\circ \pm 0.06^\circ$	$0^\circ \pm 0.14^\circ$	$0^\circ \pm 1.2^\circ$
100k Ω	$0^\circ \pm 0.18^\circ$	$0^\circ \pm 0.08^\circ$	$0^\circ \pm 0.18^\circ$	$0^\circ \pm 1.5^\circ$

1.6.5 Capacitance Reading Checks

Capacitance reading checks are made using the 100pF and 0.01 μ F capacitors summarized in Table 1-4.

NOTE

The capacitance reading check procedure is not based on instrument accuracy specifications and is included only to show that the instrument properly displays capacitance readings. As noted previously, verification of resistance measurement accuracy is sufficient to verify capacitance measurement accuracy.

Procedure:

1. Set the Model 3321/3322 operating modes as follows:
A DISPLAY: C
B DISPLAY: D
CKT MODE: SER
FREQ: 1kHz
LEVEL: 1Vrms
SPEED: MED (Model 3322 only)
RANGE: AUTO (Model 3322 only)
2. Connect the Model 3323 Direct Test Fixture to the unit (Figure 1-8), but do not connect the capacitor to the test fixture at this time.
3. Short the test fixture terminals by connecting a bare wire between them. Press ZERO SHORT, and allow the instrument to complete the zero cycle. Remove the shorting wire after the zero cycle is completed.
4. Press ZERO OPEN, and allow the instrument to complete the zero cycle.
5. Connect the 100pF, $\pm 1\%$ capacitor to the test fixture terminals, and verify that the capacitance reading is within $\pm 2\%$ of 100pF (98pF to 102pF).
6. Connect the 0.01 μ F, $\pm 1\%$ capacitor to the test fixture terminals, and verify that the capacitance reading is within $\pm 2\%$ of 10nF (9.8nF to 10.2nF).

1.6.6 Inductance Reading Checks

Inductance reading checks are made using the 100 μ H and 10mH inductors summarized in Table 1-4.

NOTE

The inductance reading check procedure is not based on instrument accuracy specifications and is included only to show that the instrument properly displays inductance readings. As noted previously, verification of resistance measurement accuracy is sufficient to verify inductance measurement accuracy.

Procedure:

1. Set the Model 3321/3322 operating modes as follows:
A DISPLAY: L
B DISPLAY: Q
CKT MODE: SER
FREQ: 1kHz
LEVEL: 1Vrms
SPEED: MED (Model 3322 only)
RANGE: AUTO (Model 3322 only)
2. Connect the Model 3323 Direct Test Fixture to the unit (Figure 1-8), but do not connect the inductor to the test fixture at this time.
3. Short the test fixture terminals by connecting a bare wire between them. Press ZERO SHORT, and allow the instrument to complete the zero cycle. Remove the shorting wire after the zero cycle is completed.
4. Press ZERO OPEN, and allow the instrument to complete the zero cycle.
5. Connect the 100 μ H, $\pm 1\%$ inductor to the test fixture terminals, and verify that the inductance reading is within $\pm 2\%$ of 100 μ H (98 μ H to 102 μ H).
6. Connect the 10mH, $\pm 1\%$ inductor to the test fixture terminals, and verify that the inductance reading is within $\pm 2\%$ of 10mH (9.8mH to 10.2mH).

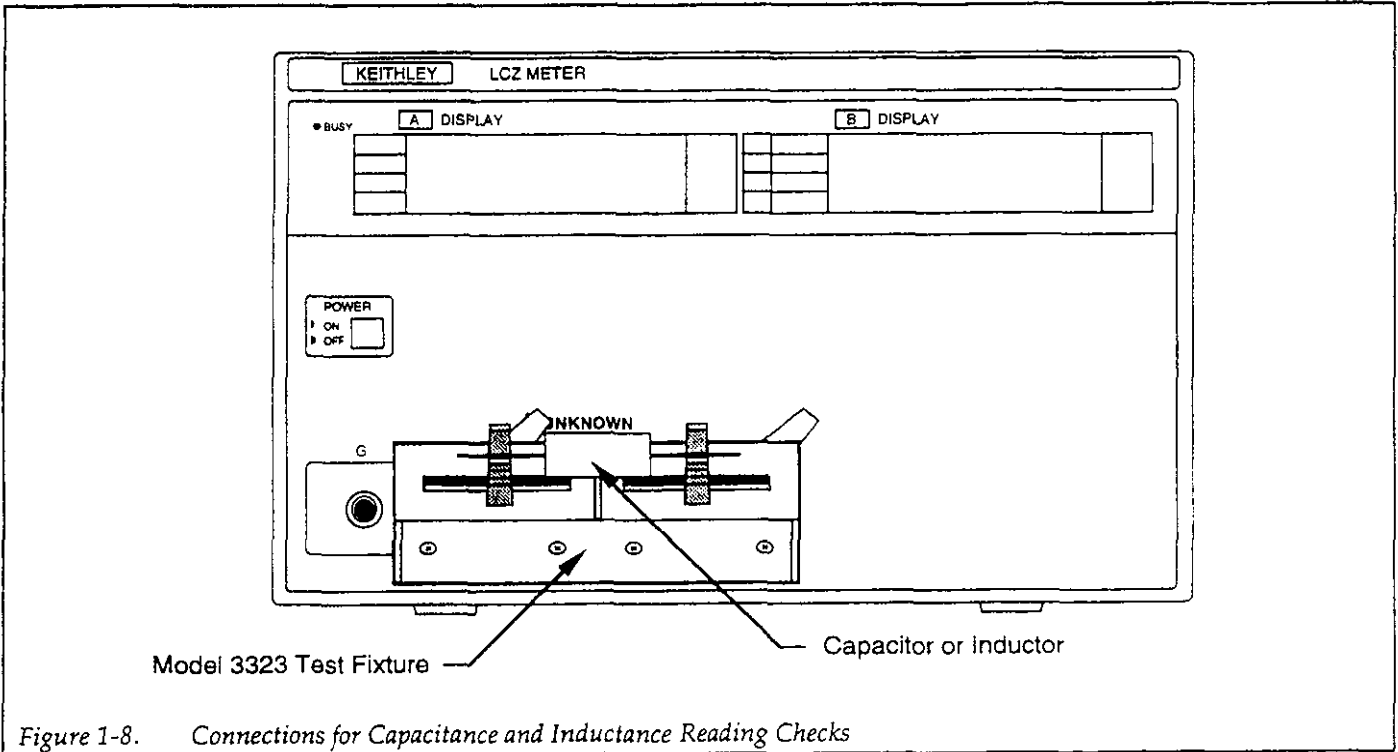

Figure 1-8. Connections for Capacitance and Inductance Reading Checks

SECTION 2

Principles of Operation

2.1 INTRODUCTION

This section discusses basic circuit operating principles for the Models 3321 and 3322.

2.2 BLOCK DIAGRAMS

Figure 2-1 shows a block diagram of the measuring system, and Figure 2-2 is a hardware block diagram.

2.3 CURRENT AND VOLTAGE DETECTION

The instrument drives the device under test (DUT) with a signal from the built-in oscillator, and it detects the current I flowing through the DUT and the voltage E_V across the DUT. The current is converted to a voltage E_I by the operational amplifier and the reference resistor R_R .

Both AC signals E_V and E_I are converted into digital data by the A/D converter. The microprocessor then multiplies these signals by the reference sine wave and integrates the resultant signal digitally to obtain the voltage and current vectors (magnitude and phase) with respect to the reference oscillator signal. Using this method, it is possible to measure only the fundamental oscillator frequency component, minimizing the effects of distortion and noise.

2.4 IMPEDANCE CALCULATION

Impedance is calculated by dividing the voltage vector by the current vector. As a result, impedance is expressed as the ratio of the magnitudes and the differences in phase between the two vectors. Any current-to-voltage conversion errors are corrected based on factors determined when the instrument is calibrated. In addition, true impedance ($Z=R_S + jX$) is obtained by correcting residual impedance Z_{SS} and floating admittance Y_{PP} , and the instrument automatically calculates main and auxiliary parameters from R_S and X .

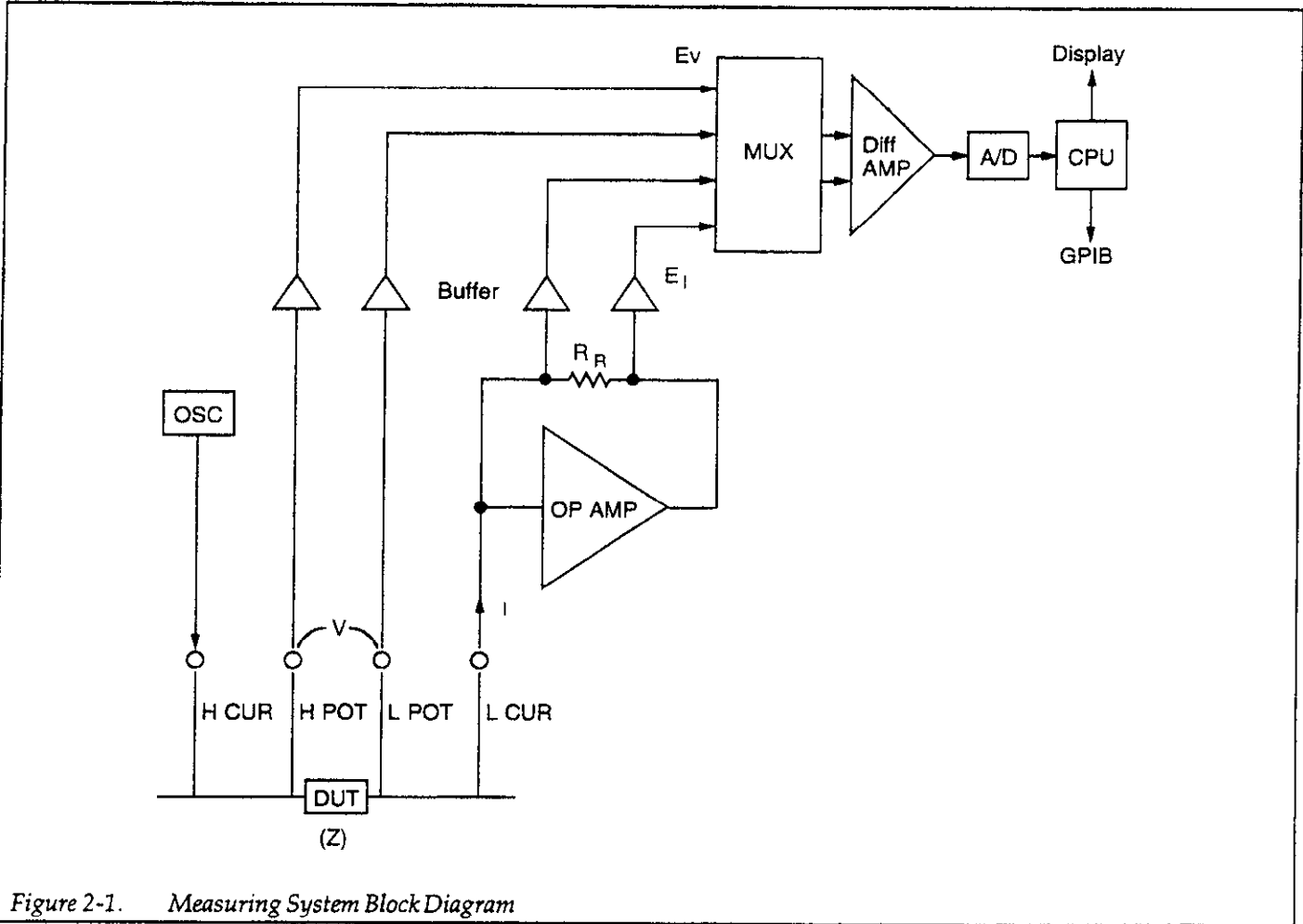

Figure 2-1. Measuring System Block Diagram

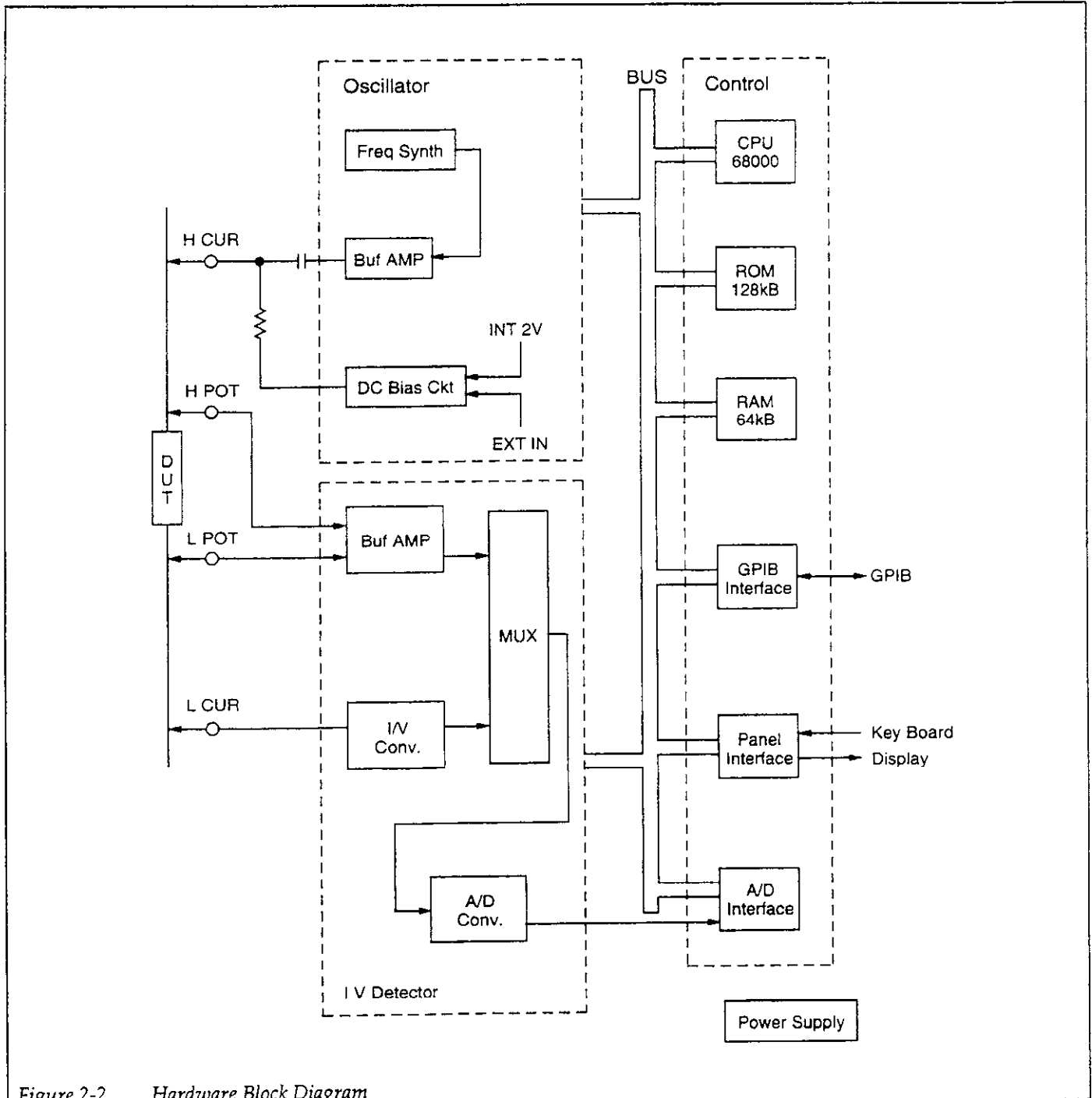

Figure 2-2. Hardware Block Diagram

2.5 OSCILLATOR

The oscillator (Figure 2-3) is a digital direct synthesis type frequency synthesizer, which uses a quartz oscillator to generate the reference frequency. The quartz oscillator is used to ensure that the synthesizer output remains stable.

The synthesizer output, which is a digital ramp signal, is converted into a sine wave by the sine ROM and is then converted into an analog signal by the D/A converter. Since the D/A converter output includes harmonics of the desired fundamental frequency, the D/A converter output signal is routed through the low-pass filter to obtain a pure sine wave.

The output of the oscillator is fed to the H CUR terminal to be applied to the DUT along with the DC bias voltage. The equivalent output impedance is approximately 100Ω.

2.6 CURRENT-TO-VOLTAGE CONVERTER

The signal current from the DUT is converted to a voltage before measurement, a function performed by the cur-

rent-to-voltage converter (Figure 2-4). The converter is made up of a high-gain operational amplifier and a reference resistor R_R , which forms the feedback loop for the op amp.

Since the operational amplifier has very high gain, its inverting input is at virtual ground potential. Consequently, the current flowing through Y_P can be neglected, and the signal current I has the same magnitude as the current flowing through R_R . As a result, the voltage across R_R , which is the same as the output voltage V_{OUT} , is simply IR_R . Note that the value of R_R can be changed according to the value of the DUT being measured in order to increase the dynamic range of the instrument.

At higher frequencies, the gain of the operational amplifier decreases, and the value of the floating admittance (which is made up primarily of capacitance at higher frequencies) increases. Consequently, the current to ground increases substantially, increasing the measurement error. The error term is proportional to the product of R_R and the square of the frequency.

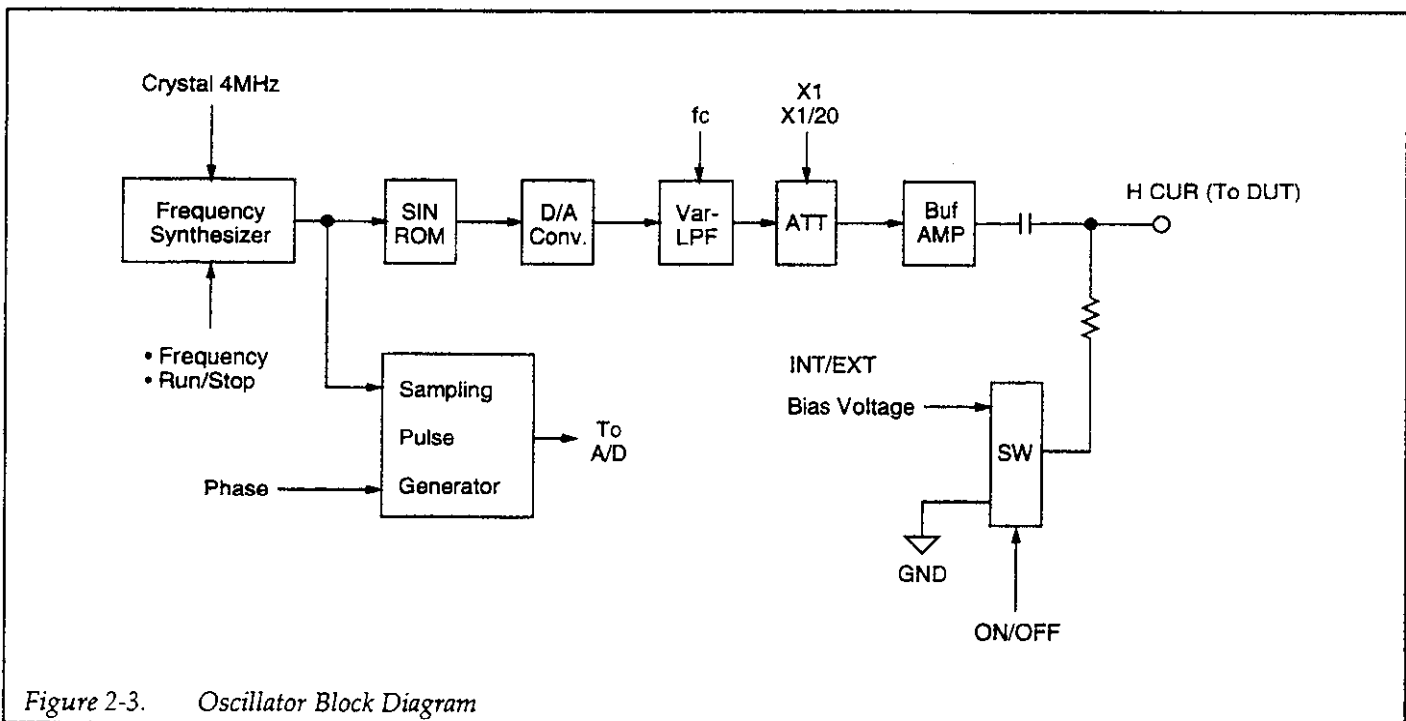

Figure 2-3. Oscillator Block Diagram

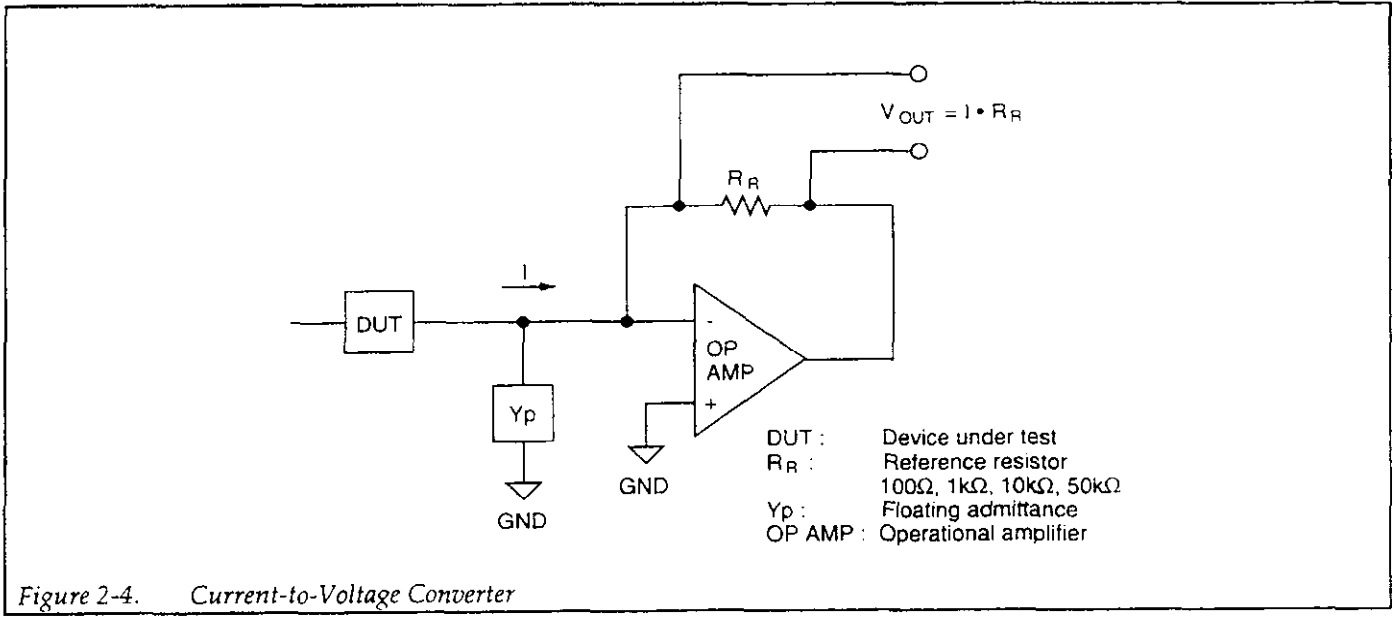

Figure 2-4. Current-to-Voltage Converter

2.7 ANALYZER

To eliminate the effects of a common-mode signal, the voltages (E_v and E_i) across the DUT and R_R are amplified by a differential amplifier and then routed to the A/D converter through a signal conditioner consisting of amplifiers and a low-pass filter (Figure 2-5). The low-pass filter attenuates any unwanted frequency components to prevent possible measurement errors.

The variable-gain amplifiers (AMP X1 and AMP X8) are used to increase the resolution of the 16-bit A/D converter when the voltage and current are small. The gain-phase characteristics are measured at power-on and in zero-measurement (OPEN and SHORT) modes, and the compensating factors are applied to subsequent impedance measurements to ensure that amplifier characteristics do not affect measurement accuracy.

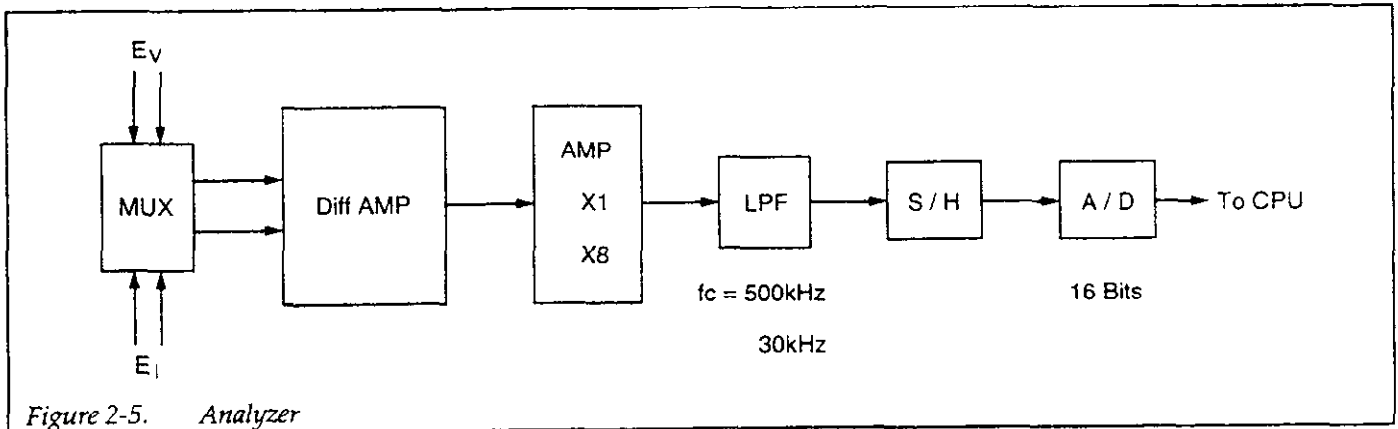

Figure 2-5. Analyzer

SECTION 3

Service Information

3.1 INTRODUCTION

This section contains information on fuse replacement, instrument repair, and replacement parts for the Model 3321/3322.

3.2 FUSE REPLACEMENT

The following paragraphs discuss replacement of the line fuse and external bias fuse.

WARNING

Disconnect the line cord and all other equipment from the instrument before replacing fuses.

CAUTION

Using the wrong fuse type may result in instrument damage.

3.2.1 Line Fuse

The line fuse, which is located on the rear panel, protects the power line input from excessive current. To replace the fuse, first unplug the line cord, then pry out the fuse holder from the bottom of the line power receptacle. Re-

place the fuse only with the type recommended in Table 3-1.

Table 3-1. Recommended Line Fuses

Line Voltage	Description	Keithley Part Number
100V/120V	1/2A, 250V, normal blow, 5mm x 20mm	FU-96-1
220V/240V	1/4A, 250V, normal blow, 5mm x 20mm	*

* Part number not available at time of printing. Contact repair department.

3.2.2 External Bias Fuse

The external bias fuse protects the instrument from excessive current supplied by an external DC bias source. To replace this fuse, simply unscrew the fuse holder, then replace with the following type: 0.1A, 250V, fast blow, 5mm x 20mm.

3.3 CALIBRATION

Model 3321/3322 calibration requires a computer program, which is available as part of a calibration kit. Cali-

bration kits are available free of charge from the factory. Please call 1-800-552-1115 to obtain your calibration kit.

3.4 FAN FILTER CLEANING

The fan filter should be cleaned at least once every three months when the unit is operated in a clean environment, or at least once a month when the unit is operated in a dirty environment. The fan filter element should be cleaned as follows:

1. Turn off instrument power, and disconnect the line cord.
2. Pry out the filter cover on the rear panel.
3. Remove the filter element.
4. Soak the filter element in a solution of mild detergent and water until clean.
5. Rinse the filter element thoroughly in clean water, then allow the filter to dry thoroughly before replacement.
6. When the filter has dried completely, install the filter and cover.

CAUTION

The instrument should not be operated without the filter in place.

3.5 REPAIR

Instrument repair may be necessary if the unit cannot be properly calibrated.

3.5.1 Factory Service

If the Model 3321/3322 is still under warranty, it is recommended that the unit be returned to the factory or

Keithley authorized repair facility for calibration or repair. When returning the unit for service, include the following:

- Complete the service form at the back of this manual.
- Advise as to the warranty status of the instrument.
- Write the following on the shipping label: ATTENTION REPAIR DEPARTMENT.

3.5.2 Cover Removal

The covers must be removed for repair. Follow the steps below to remove the covers using Figure 3-1 as a guide.

WARNING

Disconnect the line cord and all other equipment from the Model 3321/3322 before removing the covers.

CAUTION

A conductive coating is applied to the inner surfaces of the covers. Be careful not to scratch the coating when removing covers. Also be careful not to peel off the plastic film covering the front panel.

1. Place the instrument upside down on a soft cloth or rubber mat to avoid scratching the top cover.
2. Remove the four screws that secure the bottom cover, then remove the cover.
3. Place the instrument right side up.
4. Remove the top cover by separating it from the chassis.

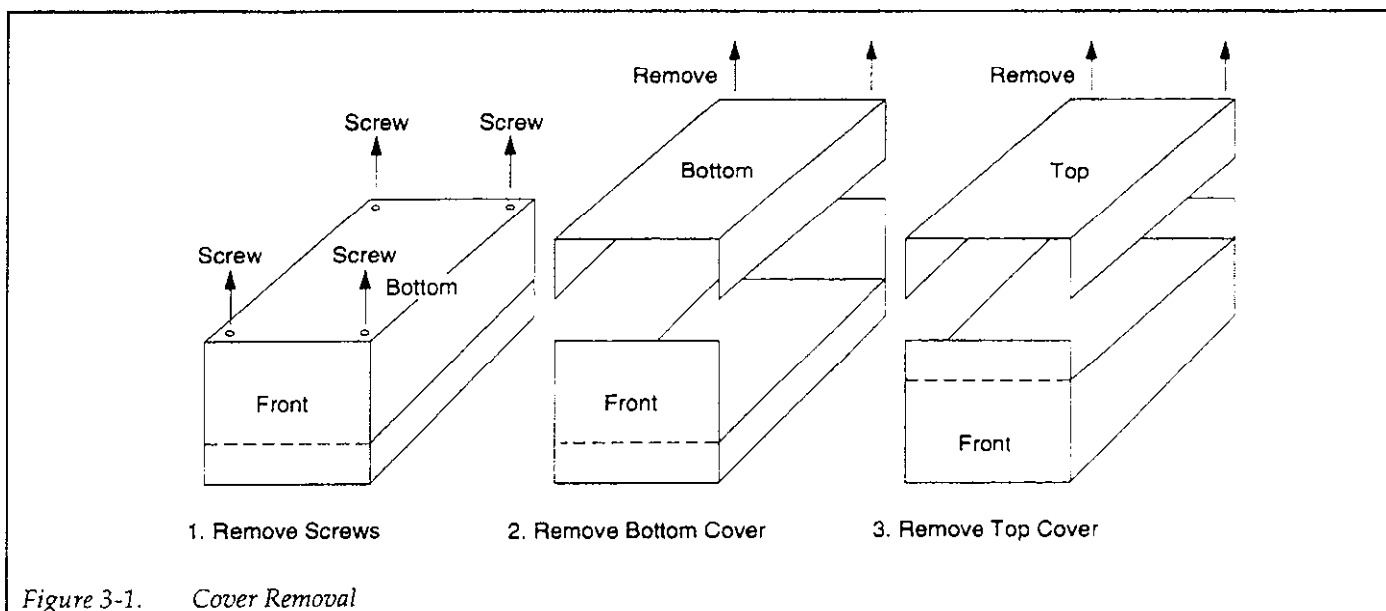

3.5.3 Battery Replacement

The battery, which backs up setup and calibration constants RAM, should last for at least three years. If you notice the instrument no longer stores setups, the battery should be replaced. (A calibration error during the self-test may also indicate a discharged battery.) Follow the steps below to replace the battery.

CAUTION

Many parts on the internal circuit boards are static sensitive. To avoid possible damage, perform any repair operations only at a properly grounded work station, and use only grounded-tip soldering irons and anti-static de-soldering tools.

Replacement of the lithium battery is normally a safe procedure as long as these safety precautions are followed.

WARNING

The precautions below must be followed to avoid possible personal injury.

1. Wear safety glasses or goggles when working with lithium batteries.
2. Do not short the battery terminals together.
3. Do not incinerate or otherwise expose to excessive heat (>60°C).

4. Keep lithium batteries away from all liquids.
5. Do not recharge lithium batteries.
6. Observe proper polarity when inserting battery into holder.

NOTE

Calibration constants are stored in battery backed up RAM. Model 3321/3322 calibration will be required if the battery becomes fully discharged, or if you remove the battery.

Procedure:

1. Disconnect the line cord and all other instruments from the Model 3321/3322.
2. Remove the top and bottom covers.
3. Note the positions of the various cables connected to the circuit board, then disconnect all cables from the board.
4. Remove the screws that secure the circuit board to the chassis.
5. Remove the control board.
6. Unsolder the battery terminal, and remove the battery.
7. Install a new battery, taking care to observe polarity.
8. Install the circuit board, and connect all cables to the board.
9. Replace the covers.
10. Calibrate the instrument after replacing the battery (see paragraph 3.3).

3.5.4 Operation Check

Procedure:

1. Connect the instrument to an appropriate power source using the supplied power cord.
2. Press in on the front panel POWER switch to turn on the power.
3. Verify that the instrument displays the ROM version number on the [A] DISPLAY area.
4. The instrument will then perform internal circuit checks and enter the self-calibration mode. During self-calibration, "CAL" is displayed on the [A] DISPLAY, and a decrementing number is displayed on the [B] DISPLAY section.
5. The number on the [B] DISPLAY section decrements; the self-calibration cycle ends when this number reaches zero.
6. If an error occurs, an appropriate message will be displayed (see Table 3-2). Turn the instrument off for three seconds, then turn power back on to see if the error clears. If the error persists and cannot be cleared, the instrument requires the indicated service.

3.5.5 Repair Summary

Table 3-3 summarizes the most likely source of the problem for the various operation check item problems (see paragraph 3.5.4). Table 3-4 summarizes actions to take for various measurement signal problems. (See Section 1 for measurement signal measurements.)

Table 3-2. Self-calibration Errors

Error	Message	Description	Recommended Action
Err	Err	Circuit abnormality	Repair instrument
EEEE	2222	Invalid cal constants	Calibrate instrument
EEEE	4444- 7777	RAM error	Check RAM
EEEE	99999	ROM error	Check ROM

Table 3-3. Operation Check Problem Summary

Problem	Action
Non-resettable error (except IEEEE 22222)	Replace RAM, ROM, or circuit board (NP-10420).
Resettable error	Reset error, and proceed with operation.
IEEEE 22222 error	Repeat test, calibrate unit if problem persists.*
Calibration error	Replace main board (NP-10420).
Front panel keys and/or LEDs do not function	Replace front panel circuit board.

* If the calibration error persists, the internal battery may require replacement.

Table 3-4. Measurement Signal Problem Summary

Problem	Action
Frequency accuracy	Replace main board (NP-104020).
Measurement signal level accuracy	Adjust output voltage (replace main board if adjustment is not effective).
Measurement signal distortion	Replace main board.
Output impedance accuracy	Replace main board.
Internal DC bias accuracy	Replace main board.
External DC bias voltage range	Replace main board.

3.6 REPLACEABLE PARTS

3.6.2 Ordering Parts

3.6.1 Parts List

Table 3-5 summarizes available Model 3321 replacement parts, and Table 3-6 lists Model 3322 parts. Figure 3-2 shows the location of mechanical parts.

To order a part, or to obtain information on replacement parts, contact your Keithley representative or the factory. When ordering parts, include the following information:

- Instrument model number
- Instrument serial number
- Keithley part number
- Part description

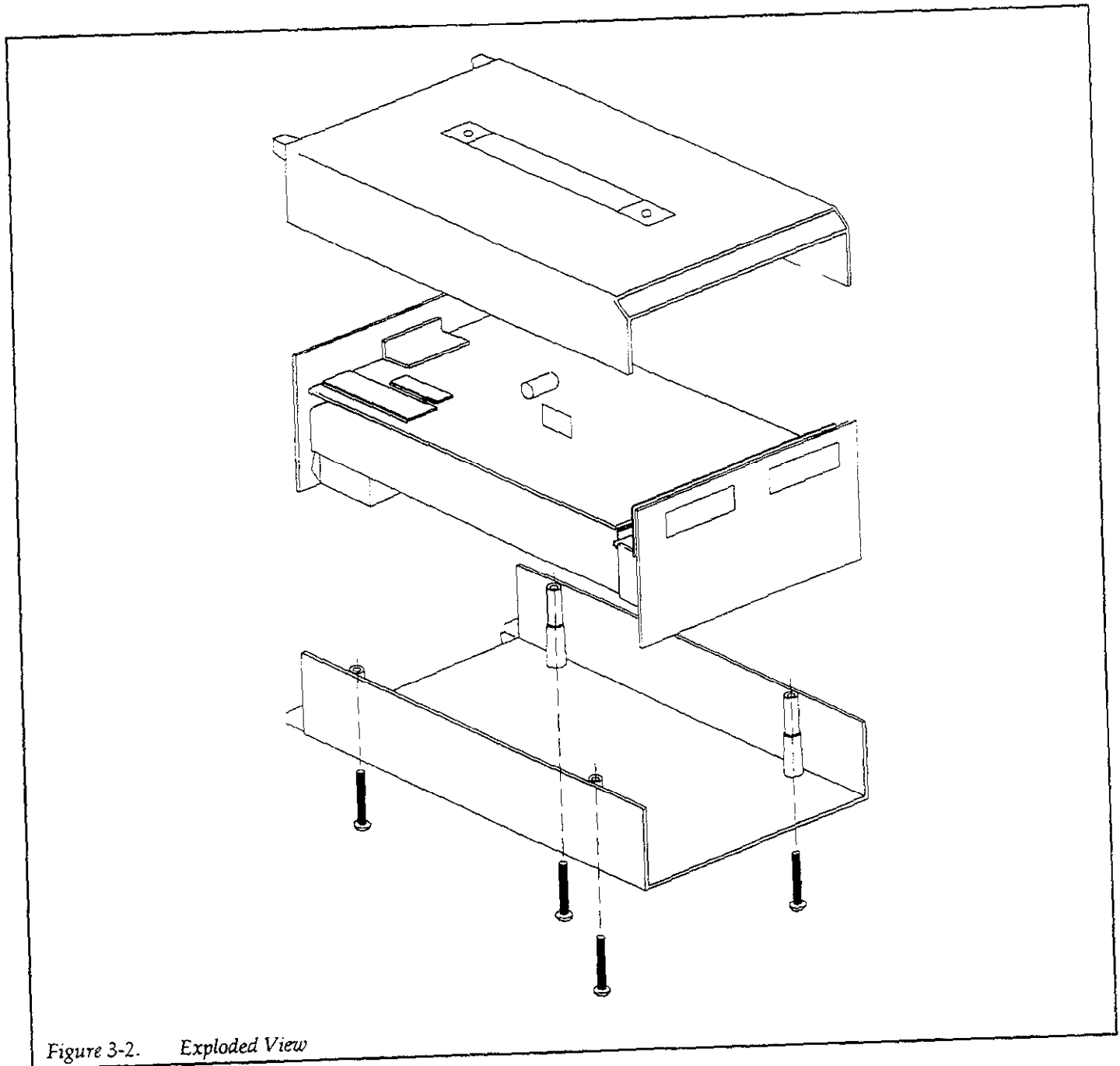

Figure 3-2. Exploded View

Table 3-5. Model 3321 Replaceable Parts

Description	Part Number	Qty.
Front Panel circuit board assembly (NP-21048)	080-33544-00	1
Main circuit board assembly (NP-10420)	080-33528-00	1
Fan	300-00785-00	1
Ground terminal (front panel)	330-05346-00	1
Ground terminal (rear panel)	330-05389-00	1
Fuse holder	302-04054-00	1
Noise filter (AC receptacle)	240-03212-00	1
Connector mounting screw	314-09865-00	2
BNC connector	310-00169-00	5
Power switch (on front panel)	332-19133-00	1
Power switch (internal)	332-19141-00	1
Flexible wire (for power switch)	332-19150-00	1
Button (for power switch)	359-03554-00	1
Voltage selecting switch	332-50057-00	1
Power transformer	244-19681-00	1
Front panel	406-03679-00	1
Rear panel	400-11674-00	1
Chassis	516-07107-00	1
Hexagonal stud (for NP-21049A-2)	606-00250-00	2
Hexagonal stud (for NP-10420)	606-00080-00	6
Air filter	459-00205-00	1
Flat head screw (for air filter)	600-01241-00	4
Grommet	546-00138-00	1
Tactile switch	332-80011-00	20
Key top (1) (gray)	436-00891-00	19
Base	436-00999-00	20
Key top (1) (orange)	436-00883-00	1
Battery (lithium)	*	1
Fuse (external bias)	*	1
Fuse (100/120V)	FU-96-1	1
Fuse (220/240V)	*	1

*Part number not available at time of printing. Contact Repair Department.

Table 3-6. Model 3322 Replaceable Parts

Description	Part Number	Qty.
Front Panel circuit board assembly (NP-21049)	080-33579-00	1
Main circuit board assembly (NP-10420)	080-33561-00	1
Fan	300-00785-00	1
Ground terminal (front panel)	330-05346-00	1
Ground terminal (rear panel)	330-05389-00	1
Fuse holder	302-04054-00	1
Noise filter (AC receptacle)	240-03212-00	1
Connector mounting screw	314-09865-00	2
BNC connector	310-00169-00	5
Power switch (on front panel)	332-19133-00	1
Power switch (internal)	332-19141-00	1
Flexible wire (for power switch)	332-19150-00	1
Button (for power switch)	359-03554-00	1
Voltage selecting switch	332-50057-00	1
Power transformer	244-19681-00	1
Front panel	406-03687-00	1
Rear panel	400-11674-00	1
Chassis	516-07107-00	1
Hexagonal stud (for NP-21049A-2)	606-00250-00	2
Hexagonal stud (for NP-10420)	606-00080-00	6
Air filter	459-00205-00	1
Flat head screw (for air filter)	600-01241-00	4
Grommet	546-00138-00	1
Tactile switch	332-80011-00	17
Key top (1) (gray)	436-00891-00	17
Base	436-00999-00	17
Battery (lithium)	*	1
Fuse (external bias)	*	1
Fuse (100/120V)	FU-96-1	1
Fuse (220/240V)	*	1

*Part number not available at time of printing. Contact Repair Department.

APPENDIX A

Model 3321 Specifications

A.1 MEASUREMENT PARAMETERS

Kinds of Parameters

- Main Parameters

AUTO: Selects the main parameters, sub-parameters and equivalent circuits automatically.

L: Self-inductance (unit: H, henry)

C: Capacitance (unit: F, farad)

|Z|: Magnitude of impedance (unit: Ω)

There are series and parallel measuring modes for each of L, C and R.

- Sub-parameters

Q: Quality factor (quality of circuit)

D: Dissipation factor ($= \tan \delta = 1/Q$)

ESR: Equivalent series resistance (unit: Ω)

G: Parallel conductance (unit: S, siemens; $1/\Omega$; Mho)

θ : Phase angle of impedance (unit: degree)

- Equivalent Circuits

AUTO: Automatic selection

SER: Series

PAR: Parallel

- Automatic Parameter Selection

Parameters can be automatically selected by the phase angle of impedance.

$\theta \approx +90^\circ \pm 45^\circ \rightarrow L - Q$

$\theta \approx -90^\circ \pm 45^\circ \rightarrow C - D$

$\theta \approx$ Other than the above $\rightarrow |Z| - \theta$

- Automatic Selection of Equivalent Circuits

Equivalent circuits can be automatically selected by the value and phase angle of impedance, and the combination of parameters.

Conditions for Selection of Series Mode	Conditions for Selection of Parallel Mode
L, C - ESR	L, C - G
L, C ($ Z \leq 1k\Omega$) - Q, D	L, C ($ Z > 1k\Omega$) - Q, D
Z - θ	

Displayed Resolution

4-1/2 digits (19999 max)

D and Q Resolution: 0.0001 min

θ Resolution: 0.01°

Measuring (display) Range

|Z|, ESR: 0.1m Ω to 19.999M Ω

C: 0.001pF to 199.99mF

L: 0.1nH to 19.999kH

Q, D: 0.0001 to 19999

G: 0.001 μ S to 199.99S

θ : -180.00° to +179.99°

These ranges are dependent on the frequency, measuring range, and phase angle of impedance.

Accuracy

Accuracy Guarantee Conditions

- Warm-up time: 30 minutes.
- Ambient temperature and humidity: 23° \pm 5°C, \leq 90% RH.
- Zero correction: Performed under the above conditions.
- Calibration period: 12 months.

Accuracy of |Z| and θ

For $0.2\Omega \leq |Z| \leq 20M\Omega$, see Table A-1.

For $|Z| < 0.2\Omega$, see Table A-2.

For $|Z| > 20M\Omega$, see Table A-3.

Notes:

1. When a measurement is made at twice line frequency, the measured value may deviate beyond the accuracy range due to interaction with line frequency.
2. When the operating temperature is 5°-40°C, add the value shown in Table A-4 to that in Table A-1. Double the values shown in Table A-2 and A-3.
3. Tables A-1 through A-3 show the worst case value in each impedance range. Obtain the correct accuracy in the following ranges by linear interpolation:
 - $|Z| = 1M$ to 20M Ω
In this range, as impedance increases, accuracy decreases.
acc1: Accuracy shown in one range below the range including a Z in Table A-1.
acc2: Accuracy (worst case value) shown in the range including a Z in Table A-1.
 - $|Z| = 0.2$ to 2 Ω
In this range, as impedance decreases, accuracy decreases.
acc1: Accuracy (worst case value) shown in the range including a Z in Table A-1.

Notes Cont.:

acc2: Accuracy shown in one range above the range including a Z in Table A-1.

$$acc = [acc1 (Z2 - Z) + acc2 (Z - Z1)] / (Z2 - Z1)$$

Z: Magnitude of measured impedance (measured value)

Z1: Lower limit value of each impedance range in Table A-1.

Z2: Upper limit value of each impedance range in Table A-1.

acc: Measuring accuracy of impedance Z (|Z| is displayed by %, and θ by degree.)

acc1: Measuring accuracy of impedance Z1

acc2: Measuring accuracy of impedance of Z2

When obtaining the accuracy in the ambient temperature ranging from 5°-40°C, add each corresponding value in Table A-4 to acc1 and acc2 in advance.

• When level = 50mV rms, accuracy is not guaranteed in the following ranges.

$$|Z| \geq 20M\Omega$$

$$|Z| \geq 2M\Omega \text{ and frequency} = 100kHz$$

$$|Z| < 0.2\Omega$$

Accuracy of ESR and G

In the case of $Q < 0.1$ ($D > 10$), use the accuracy of |Z|:

$$|ESR| = |Z|$$

$$|G| = 1/|Z|$$

Accuracy of L and C

In the case of $Q > 10$ ($D < 0.1$), use the accuracy of |Z|:

$$L = \frac{|Z|}{2\pi f}$$

$$C = \frac{1}{2\pi f |Z|}$$

where f is the test frequency in Hz.

Refer to Figure A-1, Conversion from LC to |Z|.

Accuracy of D and Q

In case $D \ll 1$ ($Q \gg 1$), use the following equations:

$$\text{Accuracy of } D = \pm(0.0175 \times \theta \text{ accuracy (deg)})$$

$$\text{Accuracy of } Q = \pm(0.0175 \times \theta \text{ accuracy (deg)} \times Q^2)$$

In any parameter, add the $\pm 1/2$ count, i.e., half of the resolution to the displayed value as actual accuracy.

Table A-1. Accuracy of $|Z|$ and θ for $0.2\Omega \leq |Z| < 20M\Omega$

$ Z $ (Ω)	LEVEL = 1V rms Frequency, (Hz)				LEVEL = 50mVrms Frequency, (Hz)			
	120	1k	10k	100k	120	1k	10k	100k
$10M \leq Z < 20M$	3.0% 1.5°	1.0% 0.8°	3.5% 2.0°	20.0% 12.0°	7.0% 4.0°	3.5% 2.0°	8.5% 5.0°	- -
$5M \leq Z < 10M$	1.5% 0.9°	0.5% 0.4°	1.8% 1.1°	10.0% 6.0°	3.5% 2.0°	1.7% 1.0°	3.5% 2.0°	- -
$2M \leq Z < 5M$	0.75% 0.45°	0.3% 0.2°	0.9% 0.6°	5.0% 3.0°	2.0% 1.2°	0.9% 0.6°	1.6% 1.0°	- -
$1M \leq Z < 2M$	0.36% 0.22°	0.2% 0.1°	0.4% 0.2°	3.0% 2.0°	1.0% 0.6°	0.4% 0.25°	0.8% 0.5°	14.0% 8.0°
$200k \leq Z < 1M$	0.25% 0.15°	0.15% 0.09°	0.27% 0.16°	2.0% 1.2°	0.5% 0.3°	0.3% 0.18°	0.4% 0.25°	7.0% 4.0°
$20k \leq Z < 200k$	0.15% 0.10°	0.1% 0.04°	0.25% 0.15°	1.2% 0.8°	0.3% 0.18°	0.16% 0.08°	0.32% 0.18°	3.0% 1.5°
$2k \leq Z < 20k$	0.14% 0.09°	0.1% 0.03°	0.15% 0.08°	0.8% 0.6°	0.25% 0.15°	0.16% 0.06°	0.24% 0.14°	2.0% 1.2°
$10 \leq Z < 2k$	0.13% 0.08°	0.1% 0.03°	0.13% 0.1°	0.7% 0.5°	0.20% 0.12°	0.15% 0.06°	0.23% 0.13°	1.6% 1.0°
$2 \leq Z < 10$	0.25% 0.15°	0.15% 0.07°	0.32% 0.2°	1.5% 0.8°	0.5% 0.3°	0.25% 0.14°	0.5% 0.3°	4.0% 2.3°
$1 \leq Z < 2$	0.35% 0.22°	0.2% 0.12°	0.5% 0.3°	2.0% 1.2°	1.0% 0.6°	0.5% 0.3°	0.8% 0.5°	8.0% 5.0°
$0.5 \leq Z < 1$	0.7% 0.45°	0.4% 0.25°	0.8% 0.5°	3.3% 2.0°	1.8% 1.1°	1.0% 0.6°	1.5% 0.9°	14.0% 8.5°
$0.2 \leq Z < 0.5$	1.4%	0.8%	1.25%	5.5%	3.7%	2.0%	2.9%	28.0%

$|Z|$ Accuracy: $\pm\%$ reading shown on upper line.

θ Accuracy: \pm degrees shown on lower line.

Table A-2. Accuracy of $|Z|$ and θ for $|Z| < 0.2\Omega$

$ Z $ (Ω)	LEVEL = 1V rms Frequency, (Hz)			
	120	1k	10k	100k
$0 \leq Z < 0.2$	1.7% +0.2m	1.0% +0.2m	1.4% +0.3m	6.0% +3m

$|Z|$ Accuracy: $\pm(\%$ reading + R) shown.

θ Accuracy: (θ Accuracy for $0.2 \leq |Z| < 0.5$ in Table A-1) $\times (0.2\Omega / |Z|)$

Table A-3. Accuracy of $|Z|$ and θ for $|Z| \geq 20M\Omega$

$ Y $ (S)	LEVEL = 1V rms Frequency, (Hz)			
	120	1k	10k	100k
$0 \leq Y \leq 50nS$	1.8nS	0.6nS	2.1nS	12nS

$|Z|$ Accuracy: Specified by the \pm deviation (S) of admittance $|Y|$ shown.
 θ Accuracy: (θ Accuracy for $10M \leq |Z| < 20M$ in Table A-1 $\times (|Z|/20M\Omega)$).

Table A-4. Additional Error for 5°-40°C

$ Z $ Ω	LEVEL = 1Vrms Frequency, (Hz)		LEVEL = 50mVrms Frequency, (Hz)	
	120 to 10k	100k	120 to 10k	100k
$10M \leq Z < 20M$	0.2% 0.12°	2.0% 1.2°	0.3% 0.2°	— —
$5M \leq Z < 10M$	0.12% 0.07°	1.0% 0.6°	0.2% 0.12°	— —
$2M \leq Z < 5M$	0.07% 0.04°	0.5% 0.3°	0.14% 0.09°	— —
$200k \leq Z < 2M$	0.04% 0.024°	0.20% 0.12°	0.1% 0.06°	0.6% 0.4°
$20k \leq Z < 200k$	0.04% 0.024°	0.20% 0.12°	0.06% 0.035°	0.3% 0.2°
$2k \leq Z < 20k$	0.04% 0.024°	0.08% 0.05°	0.06% 0.035°	0.15% 0.1°
$10 \leq Z < 2k$	0.04% 0.024°	0.08% 0.05°	0.06% 0.035°	0.15% 0.1°
$2 \leq Z < 10$	0.04% 0.024°	0.10% 0.06°	0.2% 0.12°	1.0% 0.6°
$1 \leq Z < 2$	0.07% 0.04°	0.18% 0.1°	0.4% 0.24°	2.0% 1.2°
$0.5 \leq Z < 1$	0.12% 0.07°	0.33% 0.2°	0.8% 0.5°	4.0% 3.5°
$0.2 \leq Z < 0.5$	0.2% 0.12°	0.6% 0.4°	2.0% 1.2°	10.0% 6.0°

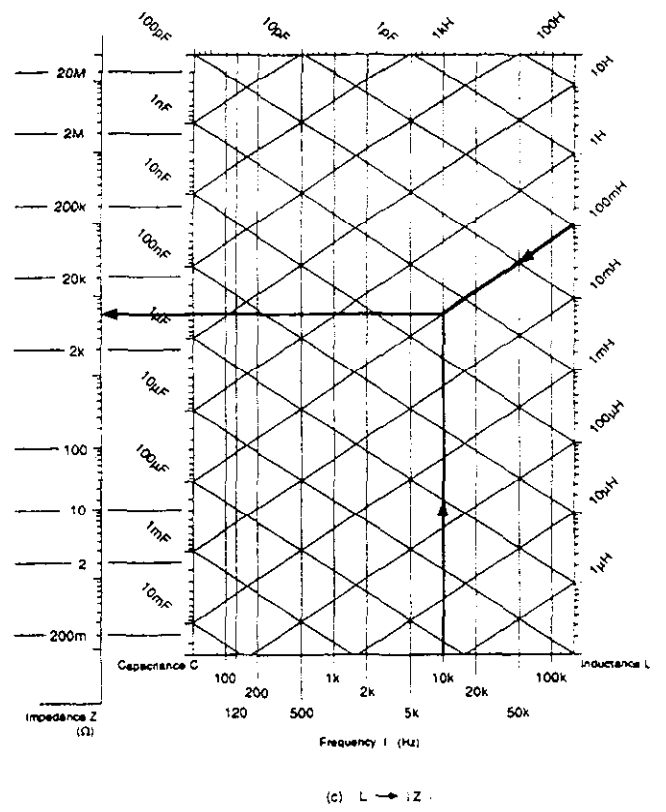
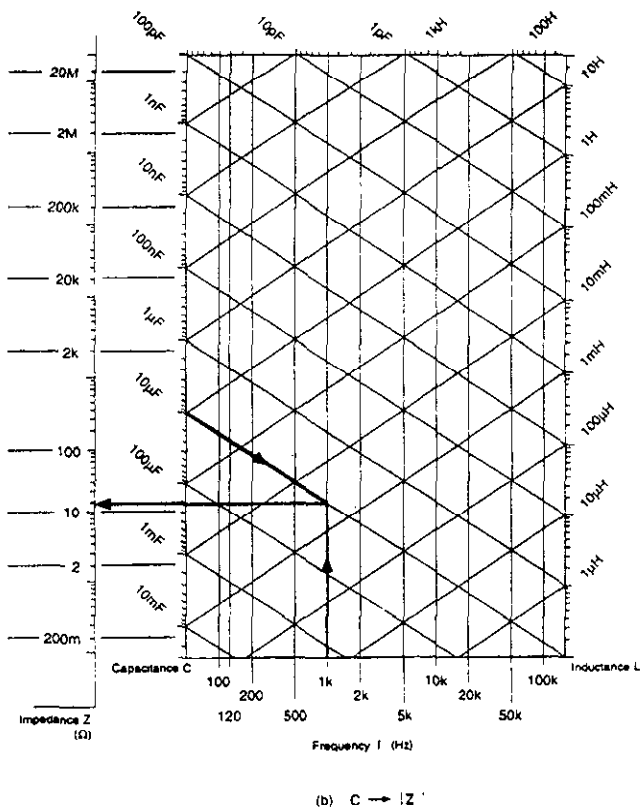
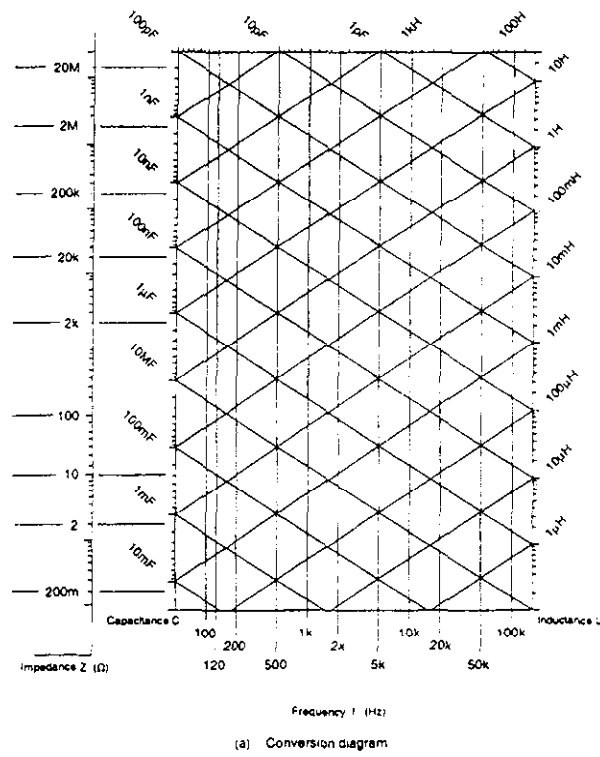

Figure A-1. Conversion Diagram from L or C to $|Z|$

Examples of Determining Accuracy

Ex. 1: Find the accuracy when $R=33k\Omega$, $f=10kHz$, $1V$, while $Q < 0.1$.

- Find the accuracy from Table A-1, using the following parameters: $1V$, $10kHz$ and $20k$ to $200k\Omega$.
- When operating within a temperature range from 5 to $40^\circ C$, add the value in Table A-4.
- When accuracy is needed for $\geq 1M\Omega$ or $\leq 2\Omega$, interpolate the value according to Note 3.
- Add $\pm 1/2$ count of display value. When the display shows a measured value of $33.14k\Omega$, the $1/2$ count becomes $0.005k\Omega$.

Ex. 2: Find the accuracy when $C = 10\mu F$, $f=1kHz$, $50mV$, while $D < 0.1$.

- Find $|Z|$ from Figure A-1 Conversion Diagram.
 - Find the line descending from $C = 10\mu F$. Find the vertical line from frequency = $1kHz$. Mark their intersection.
 - Extend a horizontal line from the intersection, to the left side. Read the value of $|Z|$ ($\approx 16\Omega$). Also, you can calculate the accuracy using the following equation.

$$|Z| = |1/2\pi f C|$$

- Find the accuracy from Table A-1, using the following parameters: $50mV$, $1kHz$ and 10 to $2k\Omega$.
- When operating within a temperature range from 5 to $40^\circ C$, add the value in Table A-4.
- When accuracy is needed for $\geq 1M\Omega$ or $\leq 2\Omega$, interpolate the value according to Note 3.
- Add $\pm 1/2$ count of display value.

Ex. 3: Find the accuracy when $L = 680\mu H$, $f=100kHz$, while $Q > 10$.

- Find $|Z|$ from Figure A-1 Conversion Diagram.
 - Draw a straight line from $L = 680\mu H$, in parallel with the ascending lines. Find the intersection with the vertical line at frequency = $100kHz$.
 - Read $|Z|$ as shown in Ex. 2. Also, you can calculate the accuracy using the following equation:

$$|Z| = |2\pi f L|$$

- Find the accuracy from Table A-1, using the following parameters: $f=100kHz$ and 10 to $2k\Omega$. Repeat procedures 3 to 5 in Ex. 2.

Ex. 4: Find the accuracy of $|Z|$ at any θ and for parameters other than θ .

- Measure $|Z|$ and θ , or calculate the accuracy, using the other parameters.

$$Q = 1/D \quad |\theta| = |\arctan Q|$$

$$= 2\pi f L_s / ESR \quad |Z| = |2\pi f L_s / \sin \theta|$$

$$= 1 / (2\pi f C_s ESR) \quad = |1 / (2\pi f C_s \sin \theta)|$$

$$= 2\pi f C_p / G \quad = |1 / (2\pi f C_p \sin \theta)|$$

$$= 1 / (2\pi f L_p G) \quad = |2\pi f L_p / \sin \theta|$$

f: Frequency (Hz)

Suffix s: Series equivalent circuit

p: Parallel equivalent circuit

- Find the accuracies of $|Z|$ and θ . Refer to Ex. 1.
- Find the maximums and minimums of $|Z|$ and θ from the measured values and accuracies of $|Z|$ and θ .

$Z_{max, min} = \text{Measured value } |Z| \times [1 \pm \text{Accuracy of } |Z| (\%)/100]$

$\theta_{max, min} = \text{Measured value } \theta \pm \text{Accuracy } \theta$ (degree)
- Find the maximums and minimums of the parameters for the four sets of combinations of maximums and minimums of $|Z|$ and θ , using the

calculating equation of each parameter. B is a susceptance, i.e., an imaginary component of admittance.

$$ESR = |Z| \cos \theta \quad G = (1/|Z|) \cos \theta$$

$$X = |Z| \sin \theta \quad B = -(1/|Z|) \sin \theta$$

$$L_s = X/2\pi f \quad L_p = -1/2\pi f B$$

$$C_s = -1/2\pi f X \quad C_p = B/2\pi f$$

$$Q = |\sin \theta| / \cos \theta \quad D = \cos \theta / |\sin \theta|$$

- The accuracy is the value that the error of $1/2$ count of display is added to $|\text{maximum value} - \text{measured value}|$ or $|\text{minimum value} - \text{measured value}|$, whichever is greater.

A.2 MEASURING SIGNAL

Frequency

Range: 120, 1k, 10k, 100k (Hz)

Accuracy: $\pm 0.005\%$ ($\pm 50\text{ppm}$)

Signal level (HCUR open voltage with terminal)

1Vrms: $\pm 3\%$ at 1kHz
 $\pm 4\%$ at 120Hz to 10kHz
 $\pm 5\%$ at 100kHz

50mVrms: $\pm 5\%$ at 1kHz
 $\pm 6\%$ at 120Hz to 10kHz
 $\pm 7\%$ at 100kHz

DC bias

Internal: 2V, $\pm 5\%$

External: 0 to 35V

A.3 MEASURING RANGE

Number of ranges: 6 (Reference resistance: 100Ω , $1k\Omega$, $10k\Omega$, $50k\Omega$, upper and lower extension ranges 2)

Selection: Automatic

A.4 MEASURING SPEED (reference value)

Measuring time (fixed range and auto trigger mode)

When the range is not switched, the following values become effective:

150ms (typ) 1kHz, $1k\Omega$

600ms (max) all ranges, all frequencies

Automatic range switching time (per range)

The automatic range switching time is nearly equal to the measuring time. When the frequency is $\leq 120\text{Hz}$ and the impedance is $\geq 1M\Omega$, it will take time for the measured value to stabilize. When measuring a device whose impedance changes according to the magnitude of the measuring signal, time will extend until the value of the device becomes stable.

Level switching stabilization time: 200ms to 4s

The level switching stabilization time will change according to the kinds of devices under test. Time increases when measuring non-linear elements, such as diodes, or when switching from $1V$ to $50mV$. This is the time required for the stabilization of measured values. The time needed to change the device under test is excluded.

Bias stabilization time: $(4 + 0.015C)s$

Where C=capacitance of device under test (μF).

Frequency switching stabilization time: 150ms to 4s

The frequency switching stabilization time increases when a high frequency is changed to a low frequency (e.g.: $100kHz$ to $120Hz$)

Also, time changes according to the device under test. This is the time required for the stabilization of the measured value. The time taken to change the device under test is excluded.

A.5 TRIGGER

Trigger mode: Automatic only.

Trigger delay time: 0 to 199.99s

A.6 MEASUREMENT TERMINALS

4 terminals (BNC) + guard terminal

A.7 SETUP MEMORY

Memory Content: All settable data (except bias on-off).

Battery Life: 3 years minimum when stored at 40°C max.

A.8 GPIB

Interface Functions: SH1, AH1, T6, L4, SR1, RL2, PP0, DC1, DT1, C0.

Setting: Of the items settable via the front panel, all the parameters except address and delimiter of GPIB can be set. Also, trigger, OPEN/SHORT compensation and memory operation can be performed.

Readout: All the settable parameters, measurement data and status.

Standards: Based on IEEE-488-1978 and IEEE-488A-1980.

Code: ISO 7 bit code (ASCII code).

A.9 GENERAL

Power requirements: AC line voltage: selectable to 100V, 120V, 220V, 240V $\pm 10\%$ (250V max.). 48 to 62Hz, approx. 21VA.

Operating Environment: 0° to 40°C, 10 to 90% RH (non-condensing).

Storage Environment: -10 to +50°C, 10 to 80% RH (non-condensing).

Dimensions, Weight: 216mm wide \times 132.5mm high \times 350mm deep (8-1/2 in. \times 5-1/4 in. \times 13-3/4 in.), excluding protrusions. Net weight 3.6kg (7.9lb.).

Figure A-2. Dimensions

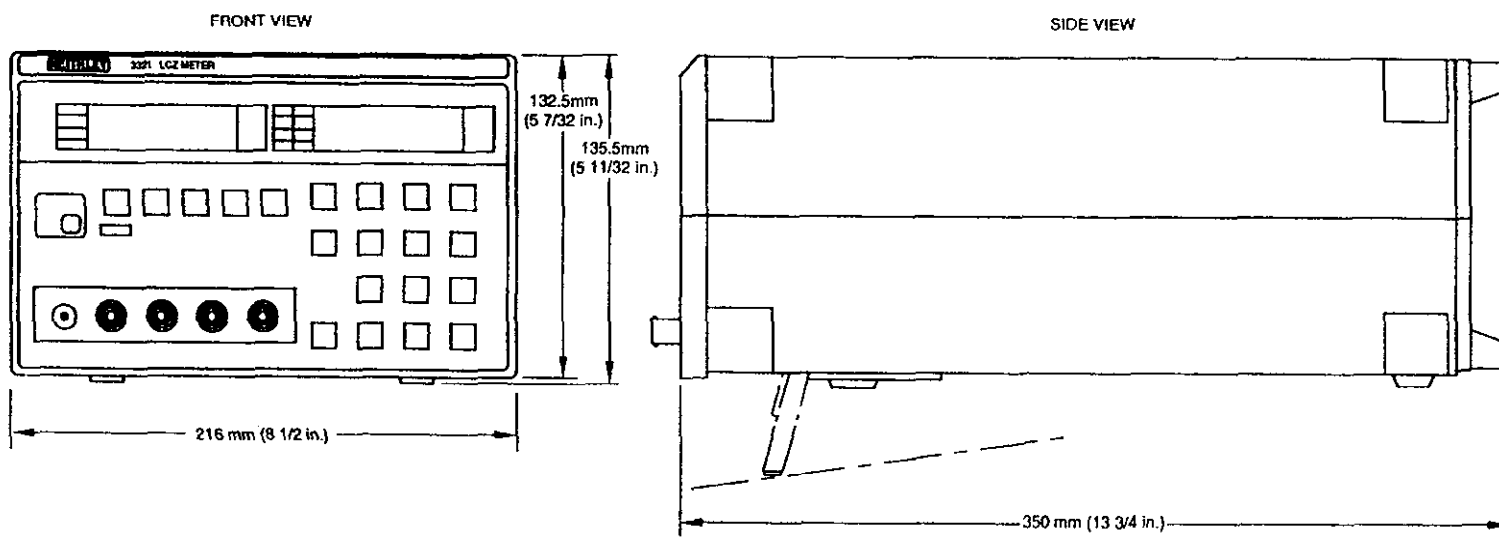

APPENDIX B

Model 3322 Specifications

B.1 MEASUREMENT PARAMETERS

Kinds of Parameters

- Main Parameters

AUTO: Selects the main parameters, sub-parameters and equivalent circuits automatically.

L: Self-inductance (unit: H, henry)

C: Capacitance (unit: F, farad)

R: Resistance (unit: Ω , ohm)

|Z|: Magnitude of impedance (unit: Ω)

There are series and parallel measuring modes for each of L, C and R.

- Sub-parameters

Q: Quality factor (quality of circuit)

D: Dissipation factor ($= \tan \delta = 1/Q$)

ESR: Equivalent series resistance (unit: Ω)

G: Parallel conductance (unit: S, siemens; 1/ Ω ; Mho)

X: Series reactance (unit: Ω)

θ : Phase angle of impedance (unit: degree)

- Equivalent Circuits

AUTO: Automatic selection

SER: Series

PAR: Parallel

- Deviation Measurement

Δ : Deviation display of main parameters (Display range $\pm 100\%$ or more)

$\Delta\%$: % deviation display of main parameters (Display range $\pm 199.99\%$)

Note: The deviation of sub-parameters cannot be displayed.

- Automatic Parameter Selection

Parameters can be automatically selected by the phase angle of impedance.

$\theta = +90^\circ \pm 30^\circ \rightarrow L - Q$

$\theta = 0^\circ \pm 30^\circ \rightarrow R - Q$

$\theta = -90^\circ \pm 30^\circ \rightarrow C - D$

$\theta = \text{Other than the above} \rightarrow |Z| - \theta$

- Automatic Selection of Equivalent Circuits

Equivalent circuits can be automatically selected by the value and phase angle of impedance, and the combination of parameters.

Conditions for Selection of Series Mode	Conditions for Selection of Parallel Mode
L, C, R, Z - ESR, X	L, C, R, Z - G
L, C (Z $\leq 1\text{k}\Omega$) - Q, D, θ	L, C (Z $> 1\text{k}\Omega$) - Q, D, θ
R ($\theta \geq 0$) - Q, D, θ	R ($\theta < 0$) - Q, D, θ
Z - Q, D, θ	

Specifications subject to change without notice.

Displayed Resolution

4-1/2 digits (19999 max)

D and Q Resolution: 0.0001 min

θ Resolution: 0.01°

Measuring (display) Range

R, |Z|, ESR, X: 0.1m Ω to 19.999M Ω

C: 0.001pF to 199.99mF

L: 0.1nH to 19.999kH

Q, D: 0.0001 to 19999

G: 0.001 μ S to 199.99S

θ : -180.00° to +179.99°

These ranges are dependent on the frequency, measuring range, and phase angle of impedance.

Accuracy

Accuracy Guarantee Conditions

- Warm-up time: 30 minutes.
- Ambient temperature and humidity: 23° \pm 5°C, \leq 90% RH.
- Zero correction: Performed under the above conditions.
- Calibration period: 12 months.

Accuracy of |Z| and θ :

For $0.2\Omega \leq |Z| \leq 20\text{M}\Omega$, see Table B-1.

For $|Z| < 0.2\Omega$, see Table B-2.

For $|Z| > 20\text{M}\Omega$, see Table B-3.

Notes:

1. When a measurement is made at twice line frequency, the measured value may deviate beyond the accuracy range due to interaction with line frequency. In this case, use 100Hz for a 60Hz line and 120Hz for a 50Hz line.
2. When the operating temperature is 5°-40°C, add the value shown in Table B-4 to that in Table B-1. Double the values shown in Table B-2 and B-3.
3. Tables B-1 through B-3 show the worst case value in each impedance range. Obtain the correct accuracy in the following ranges by linear interpolation:

- $|Z| = 1\text{M}$ to 20M Ω

In this range, as impedance increases, accuracy decreases.

acc1: Accuracy shown in one range below the range including a Z in Table B-1.

acc2: Accuracy (worst case value) shown in the range including a Z in Table B-1.

- $|Z| = 0.2$ to 2Ω

In this range, as impedance decreases, accuracy decreases.

acc1: Accuracy (worst case value) shown in the range including a Z in Table B-1.

acc2: Accuracy shown in one range above the range including a Z in Table B-1.

$$\text{acc} = \{\text{acc1} (Z2 - Z) + \text{acc2} (Z - Z1)\} / (Z2 - Z1)$$

Z: Magnitude of measured impedance (measured value)

Z1: Lower limit value of each impedance range in Table B-1.

Z2: Upper limit value of each impedance range in Table B-1.

acc: Measuring accuracy of impedance Z ($|Z|$ is displayed by %, and θ by degree.)

acc1: Measuring accuracy of impedance Z1

acc2: Measuring accuracy of impedance of Z2

When obtaining the accuracy in the ambient temperature ranging from 5°-40°C, add each corresponding value in Table B-4 to acc1 and acc2 in advance.

- Accuracy is not guaranteed in the following ranges.

$$|Z| \geq 20M\Omega$$

$$|Z| \geq 2M\Omega \text{ and frequency } \geq 50\text{kHz}$$

$$|Z| < 0.2\Omega$$

Accuracy of R, ESR and G

In the case of $Q < 0.1$ ($D > 10$), use the accuracy of $|Z|$:

$$|R| = |Z|$$

$$|ESR| = |Z|$$

$$|G| = 1/|Z|$$

Accuracy of L, C and X

In the case of $Q > 10$ ($D < 0.1$), use the accuracy of $|Z|$:

$$L = \frac{|Z|}{2\pi f}$$

$$C = \frac{1}{2\pi f |Z|}$$

$$|X| = |Z|$$

where f is the test frequency in Hz.

Refer to Figure B-1, Conversion from LC to $|Z|$.

Accuracy of D and Q

In case $D \ll 1$ ($Q \gg 1$), use the following equations:

$$\text{Accuracy of } D = \pm(0.0175 \times \theta \text{ accuracy (deg)})$$

$$\text{Accuracy of } Q = \pm(0.0175 \times \theta \text{ accuracy (deg)} \times Q^2)$$

In any parameter, add the $\pm 1/2$ count, i.e., half of the resolution to the displayed value as actual accuracy.

Table B-1. Accuracy of |Z| and θ for $0.2\Omega \leq |Z| < 20M\Omega$

Z (Ω)	LEVEL = 1V rms, SPEED = MED or SLOW								LEVEL = 50mVrms, SPEED = MED or SLOW							
	Frequency, (Hz)								Frequency, (Hz)							
	100 120	200 500	1k	2k	10k	20k	50k	100k	100 120	200 500	1k	2k 5k	10k	20k	50k	100k
10M ≤ Z < 20M	3.0%	2.0%	1.0%	2.0%	3.5%	4.0%	14.0%	20.0%	7.0%	4.5%	3.5%	6.0%	8.5%	17.0%	-	-
	1.5°	1.0°	0.8°	1.5°	2.0°	3.0°	8.0°	12.0°	4.0°	2.5°	2.0°	3.5°	5.0°	10.0°	-	-
5M ≤ Z < 10M	1.5%	1.0%	0.5%	1.0%	1.8%	2.0%	7.0%	10.0%	3.5%	2.2%	1.7%	2.7%	3.5%	7.0%	-	-
	0.9°	0.6°	0.4°	0.6°	1.1°	1.3°	4.0°	6.0°	2.0°	1.3°	1.0°	1.6°	2.0°	4.0°	-	-
2M ≤ Z < 5M	0.75%	0.5%	0.3%	0.5%	0.9%	1.0%	3.5%	5.0%	2.0%	1.2%	0.9%	1.2%	1.6%	3.5%	-	-
	0.45°	0.3°	0.2°	0.3°	0.6°	0.6°	2.0°	3.0°	1.2°	0.8°	0.6°	0.8°	1.0°	2.0°	-	-
1M ≤ Z < 2M	0.36%	0.3%	0.2%	0.3%	0.4%	0.5%	1.6%	3.0%	1.0%	0.6%	0.4%	0.6%	0.8%	1.6%	12.0%	14.0%
	0.22°	0.15°	0.1°	0.15°	0.2°	0.3°	1.0°	2.0°	0.6°	0.35°	0.25°	0.35°	0.5°	0.9°	7.0°	8.0°
200k ≤ Z < 1M	0.25%	0.2%	0.15%	0.2%	0.27%	0.35%	1.0%	2.0%	0.5%	0.4%	0.3%	0.35%	0.4%	0.7%	6.0%	7.0%
	0.15°	0.12°	0.09°	0.12°	0.16°	0.2°	0.6°	1.2°	0.3°	0.25°	0.18°	0.20°	0.25°	0.4°	3.6°	4.0°
20k ≤ Z < 200k	0.15%	0.12%	0.1%	0.18%	0.25%	0.3%	0.6%	1.2%	0.3%	0.2%	0.16%	0.24%	0.32%	0.40%	1.8%	3.0%
	0.10°	0.06°	0.04°	0.08°	0.15°	0.2°	0.4°	0.8°	0.18°	0.12°	0.08°	0.14°	0.18°	0.23°	1.0°	1.5°
2k ≤ Z < 20k	0.14%	0.12%	0.1%	0.12%	0.15%	0.2%	0.4%	0.8%	0.25%	0.18%	0.16%	0.2%	0.24%	0.35%	1.4%	2.0%
	0.09°	0.05°	0.03°	0.06°	0.08°	0.12°	0.3°	0.6°	0.15°	0.09°	0.06°	0.12°	0.14°	0.20°	0.8°	1.2°
10 ≤ Z < 2k	0.13%	0.11%	0.1%	0.11%	0.13%	0.17%	0.4%	0.7%	0.20%	0.18%	0.15%	0.20%	0.23%	0.32%	1.2%	1.6%
	0.08°	0.05°	0.03°	0.08°	0.1°	0.15°	0.25°	0.5°	0.12°	0.09°	0.06°	0.12°	0.13°	0.18°	0.7°	1.0°
2 ≤ Z < 10	0.25%	0.2%	0.15%	0.2%	0.32%	0.5%	0.8%	1.5%	0.5%	0.35%	0.25%	0.35%	0.5%	0.7%	3.4%	4.0%
	0.15°	0.1°	0.07°	0.12°	0.2°	0.3°	0.4°	0.8°	0.3°	0.20°	0.14°	0.20°	0.3°	0.4°	2.0°	2.3°
1 ≤ Z < 2	0.35%	0.3%	0.2%	0.25%	0.5%	0.7%	1.0%	2.0%	1.0%	0.6%	0.5%	0.6%	0.8%	1.1%	6.0%	8.0%
	0.22°	0.2°	0.12°	0.15°	0.3°	0.4°	0.6°	1.2°	0.6°	0.4°	0.3°	0.4°	0.5°	0.7°	3.6°	5.0°
0.5 ≤ Z < 1	0.7%	0.6%	0.4%	0.5%	0.8%	1.2%	1.7%	3.3%	1.8%	1.2%	1.0%	1.2%	1.5%	1.8%	10.0%	14.0%
	0.45°	0.4°	0.25°	0.3°	0.5°	0.7°	1.0°	2.0°	1.1°	0.7°	0.6°	0.7°	0.9°	1.1°	6.0°	8.5°
0.2 ≤ Z < 0.5	1.4%	1.1%	0.8%	1.1%	1.25%	1.8%	2.7%	5.5%	3.7%	2.6%	2.0%	2.6%	2.9%	3.4%	21.5%	28.0%
	0.9°	0.7°	0.5°	0.7°	0.8°	1.1°	1.6°	3.0°	2.2°	1.5°	1.2°	1.5°	1.7°	2.0°	13.0°	16.0°

|Z| Accuracy: ±% reading shown on upper line.

θ Accuracy: ± degrees shown on lower line.

When SPEED=FAST, accuracy is 2 times amount shown.

Table B-2. Accuracy of |Z| and θ for |Z| < 0.2 Ω

Z (Ω)	LEVEL = 1V rms, SPEED = MED or SLOW							
	Frequency, (Hz)							
	100 120	200 500	1k	2k 5k	10k	20k	50k	100k
0 ≤ Z < 0.2	1.7%	1.5%	1.0%	1.3%	1.4%	2.0%	3.0%	6.0%
	+0.2m	+0.2m	+0.2m	+0.2m	+0.3m	+0.6m	+1.5m	+3m

|Z| Accuracy: ±(% reading + R) shown.

θ Accuracy: (θ Accuracy for $0.2\Omega \leq |Z| < 0.5$ in Table B-1) \times (0.2 Ω / |Z|)

When SPEED=FAST, accuracy is 2 times amount shown.

Table B-3. Accuracy of |Y| and θ for |Z| ≥ 20M Ω

Y (S)	LEVEL = 1V rms, SPEED = MED or SLOW							
	Frequency, (Hz)							
	100 120	200 500	1k	2k 5k	10k	20k	50k	100k
0 ≤ Y ≤ 50nS	1.8nS	1.2nS	0.6nS	1.2nS	2.1nS	2.4nS	7.5nS	12nS

|Z| Accuracy: Specified by the ± deviation (S) of admittance |Y| shown.

θ Accuracy: (θ Accuracy for $10M\Omega \leq |Z| < 20M\Omega$ in Table B-1) \times (|Z| / 20M Ω).

When SPEED=FAST, accuracy is 2 times amount shown.

Table B-4. Additional Error for 5°-40°C

Z Ω	LEVEL = 1Vrms Frequency, (Hz)			LEVEL = 50mVrms Frequency, (Hz)		
	100 to 10k	20k	50k to 100k	100 to 10k	20k	50k to 100k
10M ≤ Z < 20M	0.2% 0.12°	1.0% 0.6°	2.0% 1.2°	0.3% 0.2°	3.0% 2.0°	— —
5M ≤ Z < 10M	0.12% 0.07°	0.5% 0.3°	1.0% 0.6°	0.2% 0.12°	1.5% 0.9°	— —
2M ≤ Z < 5M	0.07% 0.04°	0.25% 0.15°	0.5% 0.3°	0.14% 0.09°	0.75% 0.5°	— —
200k ≤ Z < 2M	0.04% 0.024°	0.10% 0.06°	0.20% 0.12°	0.1% 0.06°	0.3% 0.2°	0.6% 0.4°
20k ≤ Z < 200k	0.04% 0.024°	0.10% 0.06°	0.20% 0.12°	0.06% 0.035°	0.15% 0.10°	0.3% 0.2°
2k ≤ Z < 20k	0.04% 0.024°	0.04% 0.024°	0.08% 0.05°	0.06% 0.035°	0.06% 0.035°	0.15% 0.1°
10 ≤ Z < 2k	0.04% 0.024°	0.04% 0.024°	0.08% 0.05°	0.06% 0.035°	0.06% 0.035°	0.15% 0.1°
2 ≤ Z < 10	0.04% 0.024°	0.05% 0.03°	0.10% 0.06°	0.2% 0.12°	0.3% 0.2°	1.0% 0.6°
1 ≤ Z < 2	0.07% 0.04°	0.08% 0.05°	0.18% 0.1°	0.4% 0.24°	0.6% 0.4°	2.0% 1.2°
0.5 ≤ Z < 1	0.12% 0.07°	0.13% 0.08°	0.33% 0.2°	0.8% 0.5°	1.2% 0.7°	4.0% 3.5°
0.2 ≤ Z < 0.5	0.2% 0.12°	0.2% 0.12°	0.6% 0.4°	2.0% 1.2°	3.0% 2.0°	10.0% 6.0°

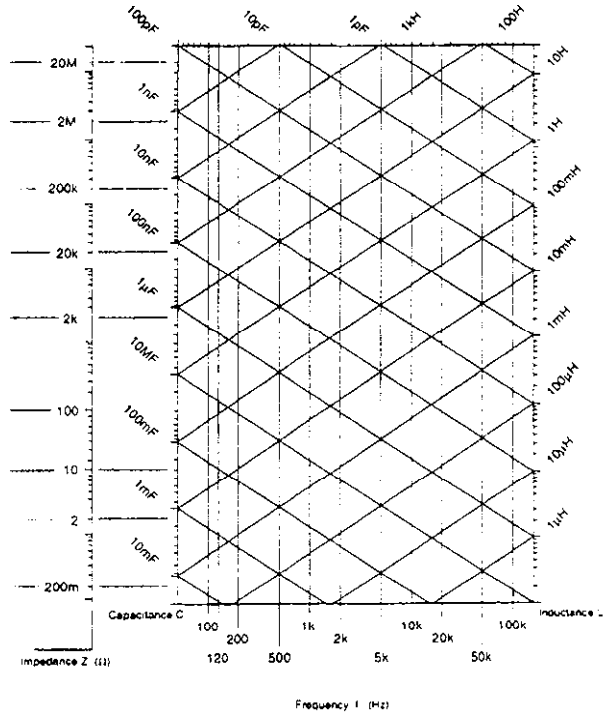

(a) Conversion diagram

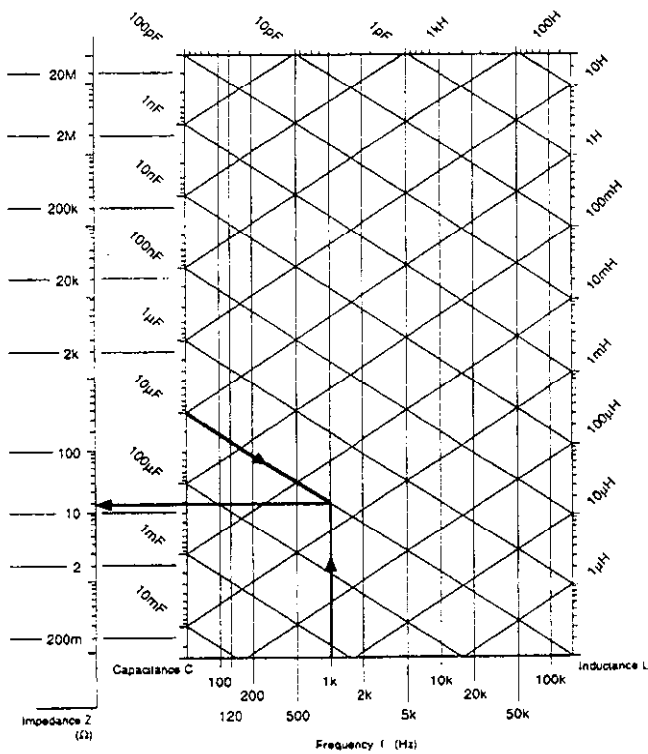

(b) $C \rightarrow |Z|$

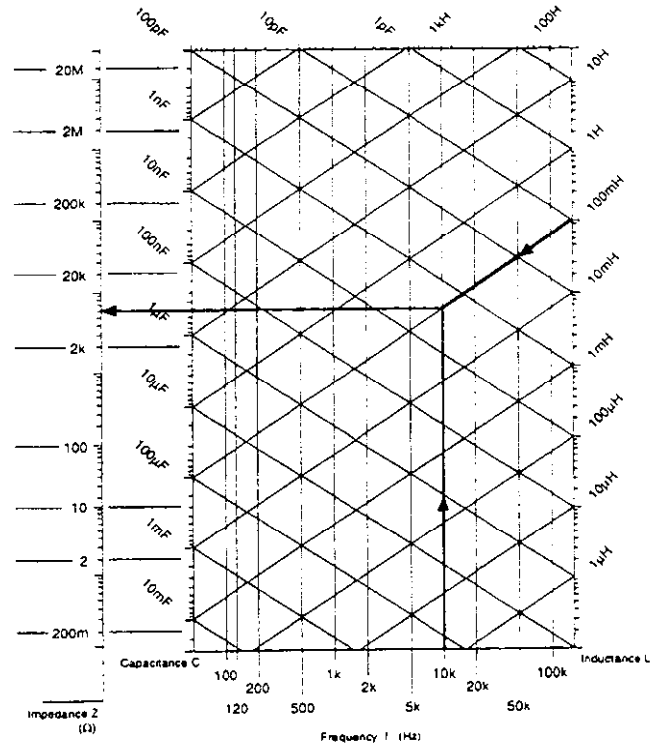

(c) $L \rightarrow |Z|$

Figure B-1. Conversion Diagram from L or C to $|Z|$

Examples of Determining Accuracy

Ex. 1: Find the accuracy when $R=33k\Omega$, $f=10kHz$, $1V$, while $Q<0.1$.

1. Find the accuracy from Table B-1, using the following parameters: $1V$, $10kHz$ and $20k$ to $200k\Omega$.
2. When the measuring speed is set to FAST, double the accuracy value.
3. When operating within a temperature range from 5 to $40^\circ C$, add the value in Table B-4.
4. When accuracy is needed for $\geq 1M\Omega$ or $\leq 2\Omega$, interpolate the value according to Note 3.
5. Add $\pm 1/2$ count of display value. When the display shows a measured value of $33.14k\Omega$, the $1/2$ count becomes $0.005k\Omega$.

Ex. 2: Find the accuracy when $C = 10\mu F$, $f=1kHz$, $50mV$, while $D < 0.1$.

1. Find $|Z|$ from Figure B-1 Conversion Diagram.
 - Find the line descending from $C = 10\mu F$. Find the vertical line from frequency = $1kHz$. Mark their intersection.
 - Extend a horizontal line from the intersection, to the left side. Read the value of $|Z|$ ($\approx 16\Omega$). Also, you can calculate the accuracy using the following equation.

$$|Z| = 1/2\pi f C$$

2. Find the accuracy from Table B-1, using the following parameters: $50mV$, $1kHz$ and 10 to $2k\Omega$.
3. When the measuring speed is set to FAST, double the accuracy value.
4. When operating within a temperature range from 5 to $40^\circ C$, add the value in Table B-4.
5. When accuracy is needed for $\geq 1M\Omega$ or $\leq 2\Omega$, interpolate the value according to Note 3.
6. Add $\pm 1/2$ count of display value.

Ex. 3: Find the accuracy when $L = 680\mu H$, $f=100kHz$, while $Q > 10$.

1. Find $|Z|$ from Figure B-1 Conversion Diagram.
 - Draw a straight line from $L = 680\mu H$, in parallel with the ascending lines. Find the intersection with the vertical line at frequency = $100kHz$.
 - Read $|Z|$ as shown in Ex. 2. Also, you can calculate the accuracy using the following equation:

$$|Z| = 12\pi f L$$

2. Find the accuracy from Table B-1, using the following parameters: $f=100kHz$ and 10 to $2k\Omega$. Repeat procedures 3 to 6 in Ex. 2.

Ex. 4: Find the accuracy of $|Z|$ at any θ and for parameters other than θ .

1. Measure $|Z|$ and θ , or calculate the accuracy, using the other parameters.

$$\begin{aligned} Q &= 1/D & |\theta| &= |\arctan Q| \\ &= 2\pi f L_s / ESR & |z| &= 12\pi f L_s / \sin \theta \\ &= 1 / (2\pi f C_s ESR) & &= 1 / (2\pi f C_s \sin \theta) \\ &= 2\pi f C_p / G & &= 1 / (2\pi f C_p \sin \theta) \\ &= 1 / (2\pi f L_p G) & &= 12\pi f L_p / \sin \theta \end{aligned}$$

f: Frequency (Hz)

Suffix s: Series equivalent circuit

p: Parallel equivalent circuit

2. Find the accuracies of $|Z|$ and θ . Refer to Ex. 1.
3. Find the maximums and minimums of $|Z|$ and θ from the measured values and accuracies of $|Z|$ and θ .

$$Z_{\max, \min} = \text{Measured value } |Z| \times [1 \pm \text{Accuracy of } |Z| (\%) / 100]$$

$$\theta_{\max, \min} = \text{Measured value } \theta \pm \text{Accuracy } \theta \text{ (degree)}$$

4. Find the maximums and minimums of the parameters for the four sets of combinations of maximums and minimums of $|Z|$ and θ , using the calculating equation of each parameter. B is a susceptance, i.e., an imaginary component of admittance.

$$\begin{aligned} R_s &= |Z| \cos \theta & R_p &= |Z| / \cos \theta \\ ESR &= |Z| \cos \theta & G &= (1 / |Z|) \cos \theta \\ X &= |Z| \sin \theta & B &= -(1 / |Z|) \sin \theta \\ L_s &= X / 2\pi f & L_p &= -1 / 2\pi f B \\ C_s &= -1 / 2\pi f X & C_p &= B / 2\pi f \\ Q &= |\sin \theta| / \cos \theta & D &= \cos \theta / |\sin \theta| \end{aligned}$$

5. The accuracy is the value that the error of $1/2$ count of display is added to |maximum value - measured value| or |minimum value - measured value|, whichever is greater.

B.2 MEASURING SIGNAL

Frequency

Range: $100, 120, 200, 500, 1k, 2k, 5k, 10k, 20k, 50k, 100k$ (Hz)

Accuracy: $\pm 0.005\%$ ($\pm 50ppm$)

Signal level (HCUR open voltage with terminal)

1Vrms: $\pm 3\%$ at $1kHz$
 $\pm 4\%$ at $100Hz$ to $20kHz$
 $\pm 5\%$ at $50kHz$ and $100kHz$

50mVrms: $\pm 5\%$ at $1kHz$
 $\pm 6\%$ at $100Hz$ to $20kHz$
 $\pm 7\%$ at $50kHz$ and $100kHz$

DC bias

Internal: $2V, \pm 5\%$

External: 0 to $35V$

B.3 MEASURING RANGE

Number of ranges: 6 (Reference resistance: $100\Omega, 1k\Omega, 10k\Omega, 50k\Omega$, upper and lower extension ranges 2)

Selection: Automatic or manual

B.4 MEASURING SPEED (reference value)

Measuring time (fixed range and auto trigger mode)

	Typical at $1kHz, 1k\Omega$	Maximum on any range, any frequency
FAST:	64ms	80ms
MED:	150ms	245ms
SLOW:	480ms	600ms

Automatic range switching time (per range)

The automatic range switching time is nearly equal to the measuring time. When the frequency is $500Hz$ and the impedance is $\geq 1M\Omega$, it will take time for the measured value to stabilize. When measuring a device whose impedance changes according to the magnitude of the measuring signal, time will extend until the value of the device becomes stable.

Level switching stabilization time: 200ms to 4s

The level switching stabilization time will change according to the kinds of devices under test. Time increases when measuring non-linear elements, such as diodes, or when switching from $1V$ to $50mV$. This is the time required for the stabilization of measured values. The time needed to change the device under test is excluded.

Bias stabilization time: $(4 + 0.015C)s$

Where C=capacitance of device under test (μF).

Frequency switching stabilization time: 150ms to 4s

The frequency switching stabilization time increases when a high frequency is changed to a low frequency (e.g.: $100kHz$ to $120Hz$)

MEASURING SPEED (reference value) (Cont.)

Also, time changes according to the device under test. This is the time required for the stabilization of the measured value. The time taken to change the device under test is excluded.

B.5 TRIGGER

Trigger modes: Automatic (repeat) and manual

Trigger delay time: 0 to 199.99s

B.6 MEASUREMENT TERMINALS

4 terminals (BNC) + guard terminal

B.7 COMPARATOR FUNCTIONS

Number of categories: 20 max.

Main parameter judgement: 1 to 19 sets of upper and lower limits can be set.

Sub-parameter judgement: 1 set of upper and lower limits can be judged.

B.8 SETUP MEMORIES

Number of Setups: 10. One of the 10 setups saves the data at power off.

Memory Content: All settable data (except bias on-off).

Battery Life: 3 years minimum when stored at 40°C max.

B.9 GPIB

Interface Functions: SH1, AH1, T6, L4, SR1, RL2, PP0, DC1, DT1, C0.

Setting: Of the items settable via the front panel, all the parameters except address and delimiter of GPIB can be set. Also, trigger, OPEN/SHORT compensation and memory operation can be performed.

Readout: All the settable parameters, measurement data and status.

Standards: Based on IEEE-488-1978 and IEEE-488A-1980.

Code: ISO 7 bit code (ASCII code).

B.10 GENERAL

Power requirements: AC line voltage: selectable to 100V, 120V, 220V, 240V $\pm 10\%$ (250V max.). 48 to 62Hz, approx. 21VA.

Operating Environment: 0° to 40°C, 10 to 90% RH (non-condensing).

Storage Environment: -10 to +50°C, 10 to 80% RH (non-condensing).

Dimensions, Weight: 216mm wide \times 132.5mm high \times 350mm deep (8-1/2 in. \times 5-1/4 in. \times 13-3/4 in.), excluding protrusions. Net weight 3.6kg (7.9lb.).

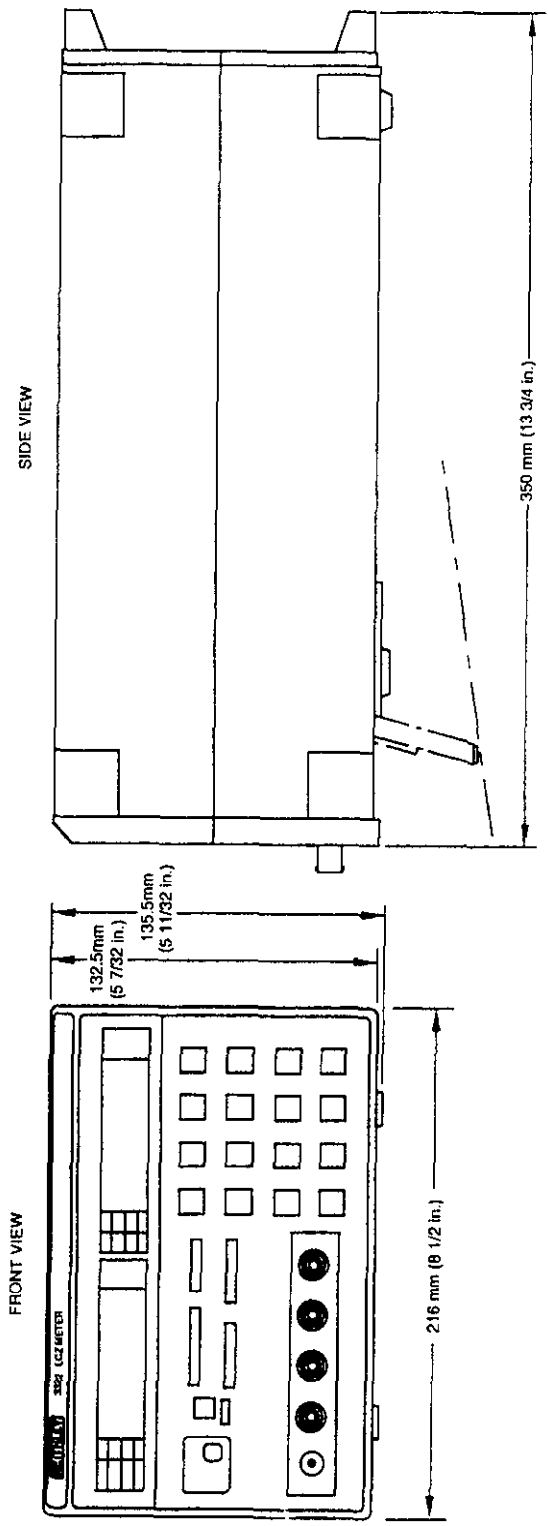

Figure B-2. Dimensions

Index

A

Analyzer, 2-5

B

Battery Replacement, 3-3

Block Diagram, 2-1

C

Calibration, 3-1

Capacitance Reading Checks, 1-12

Cover Removal, 3-2

Current and Voltage Detection, 2-1

Current-to-Voltage Converter, 2-4

E

Environmental Conditions, 1-2, 1-8

External Bias Fuse, 3-1

External DC Bias Voltage Range, 1-7

F

Factory Service, 3-2

Fan Filter Cleaning, 3-2

Frequency Accuracy, 1-2

Fuse Replacement, 3-1

I

Impedance Calculation, 2-1

Inductance Reading Checks, 1-12

Initial Conditions, 1-1

Internal Bias Voltage Accuracy, 1-6

L

Line Fuse, 3-1

Line Power, 1-1

M

Measurement Accuracy Tests, 1-8

Measurement Signal Distortion, 1-4

Measurement Signal Level Accuracy, 1-3

Measurement Signal Tests, 1-2

O

Operation Check, 3-4

Ordering Parts, 3-5

Oscillator, 2-4

Output Impedance Accuracy, 1-5

P

Parts List, 3-5

Performance Verification, 1-1

Principles of Operation, 2-1

R

Recommended Equipment, 1-8

Recommended Test Equipment, 1-2

Repair, 3-2

Repair Summary, 3-4

Replaceable Parts, 3-5

Resistance Measurement Accuracy, 1-9

Resistance Standards Accuracy, 1-8

S

Service Information, 3-1

V

Verification Limits, 1-1



Service Form

Model No. _____ Serial No. _____ Date _____

Name and Telephone No. _____

Company _____

List all control settings, describe problem and check boxes that apply to problem. _____

- Intermittent
- IEEE failure
- Front panel operational
- Analog output follows display
- Obvious problem on power-up
- All ranges or functions are bad
- Particular range or function bad; specify _____
- Batteries and fuses are OK
- Checked all cables

Display or output (check one)

- Drifts
- Unstable
- Overload
- Unable to zero
- Will not read applied input

- Calibration only
- Data required
- Certificate of calibration required

(attach any additional sheets as necessary)

Show a block diagram of your measurement system including all instruments connected (whether power is turned on or not). Also, describe signal source.

Where is the measurement being performed? (factory, controlled laboratory, out-of-doors, etc.) _____

What power line voltage is used? _____ Ambient temperature? _____ °F

Relative humidity? _____ Other? _____

Any additional information. (If special modifications have been made by the user, please describe.) _____

Be sure to include your name and phone number on this service form.